

SERVICE INSTRUCTIONS

“P-A” OR “P-B” ELECTRONIC PRESSURE COMPENSATOR FOR PVG -048/-065/-075 B-FRAME PUMP, F1U SERIES CONTROLS

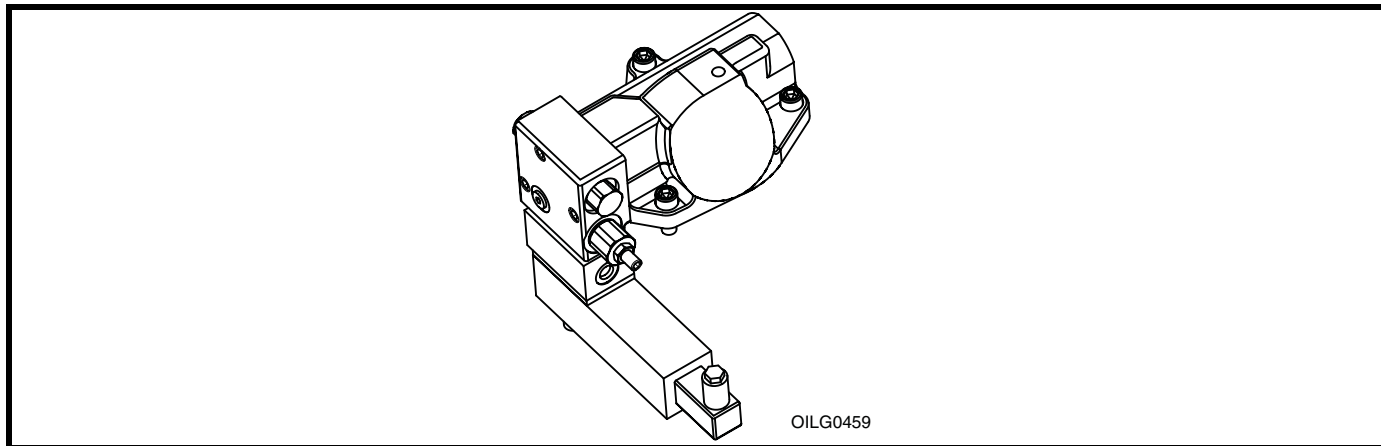

Figure 1. Typical Oilgear Type “P-A” or “P-B” Electronic Pressure Compensator, F1U Series Controls for “PVG” -048/-065/-075 B-Frame Pumps

PURPOSE OF INSTRUCTIONS

These instructions will simplify the installation, operation, troubleshooting and maintenance of Oilgear type “P-A” or “P-B” Electronic Pressure Compensator, Series F1U controlled units.

This material will inform you about the basic construction, principle of operation and service parts listings. Some controls may be modified for specific applications from those described in this bulletin and other changes may be made without notice.

REFERENCE MATERIAL

Fluid Recommendations	Bulletin 90000
Contamination Evaluation Guide.....	Bulletin 90004
Filtration Recommendations	Bulletin 90007
Piping Information	Bulletin 90011
Installation of Vertically Mounted Axial Piston Units	Bulletin 90014
PVG Pumps - 048/065/075 (F1U Series) Service Instructions	Bulletin 947023
PVG Open Loop Pumps, Sales	Bulletin 47019-I

PVG F1U SERIES PUMP INSTALLATIONS

Electronic Pressure Compensator “P-A” or “P-B” Series F1U, Installation (Dec., 2007)	Data Sheet 47546D
Amplifier Control “A”, Installation, Parts, Performance (Nov., 1997)	Data Sheet 47442
Rear Ported Basic Pump, Installation	Data Sheet 47952B
Side Ported Basic Pump, Installation	Data Sheet 47953C
Through Shaft Basic Pump, Installation	Data Sheet 47954A
Gear Pump, Installation.....	Data Sheet 47945
Dual Pump Adapters, Installation.....	Data Sheet 47958

THE OILGEAR COMPANY
2300 South 51st Street
Milwaukee, Wisconsin 53219
www.oilgear.com

Safety First

Read and understand this entire instruction sheet before repairing or adjusting your Oilgear product.

Those who use and maintain this equipment must be thoroughly trained and familiar with the product. If incorrectly used or maintained, this product and its equipment can cause severe injury.

SAFETY SYMBOLS

The following signal words are used in this instruction sheet to identify areas of concern where your safety may be involved. Carefully read the text and observe any instructions provided to ensure your safety.

DANGER

THIS SIGNAL WORD INDICATES AN IMMEDIATELY HAZARDOUS SITUATION WHICH, IF NOT AVOIDED, WILL RESULT IN DEATH OR SERIOUS INJURY.

WARNING

This signal word indicates a potentially hazardous situation which, if not avoided, could result in death or serious injury.

CAUTION

This signal word indicates that a potentially hazardous situation exists which, if not avoided, may result in damage to equipment or minor personal injury.

NOTE

While not directly relevant to the topic being discussed, the NOTE is used to emphasize information provided, or provide additional information which may be of benefit.

WARNING

This service information is designed for the maintenance of your Oilgear product. It contains the information on the correct procedures determined by Oilgear for the safe manner of servicing. Always keep this instruction sheet in a location where it is readily available for the persons who use and maintain the product. Additional copies of this instruction sheet are available through Oilgear. Contact us at 414-327-1700 or visit our website: www.oilgear.com. Please contact us if you have any questions regarding the information in this instruction bulletin.

NOTE

The cleanliness of working on this pump control or the hydraulic system is extremely important to the safety and reliability of the pump and the system. Always make sure the fittings are clean on the outside before removing them from their connections, are capped and plugged when removed, and are placed in a clean rag or container until they are reinstalled.

WARNING

Some service operations may require special tools or equipment. If you require information on these items, please contact Oilgear before attempting these repairs and service operations.

WARNING

Read, understand and follow the safety guidelines, dangers and warnings contained in this instruction sheet to promote reliable operation and prevent serious personal injury.

WARNING

DO NOT attempt to service this machinery in an environment where safety regulations are not established and in place.

WARNING

DO NOT operate the hydraulic system if a leak is present. Serious injury may result.

WARNING

Hydraulic systems operate under very high pressure. Hydraulic fluid escaping from a pressurized system can penetrate unprotected body tissue. DO NOT inspect for hydraulic leaks with bare hands or other exposed body parts. As a minimum, wear leather gloves prior to inspecting for leaks and use cardboard or wood. If leaks are present, relieve pressure and allow system to cool prior to servicing. If injured by escaping hydraulic oil, contact a physician immediately. Serious complications may arise if not treated immediately. If you have questions regarding inspecting for hydraulic leaks, please contact Oilgear prior to servicing.

⚠ WARNING

Hydraulic hoses and tubing must be inspected on a daily basis for leaks, cuts, abrasions, damage and improper clearance along any mounting frame for hidden damage before the unit is put into service. Replace damaged hoses or hoses you suspect are damaged before the system is returned to service! Hoses must be replaced every 2 years. Failure to properly inspect and maintain the system may result in serious injury.

⚠ WARNING

Hydraulic systems are hot. **DO NOT TOUCH!** Serious personal injury may result from hot oil. When you have completed working on the hydraulic system, thoroughly clean any spilled oil from the equipment. Do not spill any hydraulic fluids on the ground. Clean any hydraulic fluids from your skin as soon as you have completed maintenance and repairs. Dispose of used oil and system filters as required by law.

⚠ WARNING

Use hoses, fittings and adapters with the correct SAE rating when replacing hoses to prevent possible serious injury. Always replace hoses, fittings and adapters with replacements that have a proper, suitable, working pressure rating. Replacement hoses must be of the correct length and must comply with the hose manufacturer's and Oilgear's installation guidelines and recommendations.

⚠ WARNING

Hydraulic hoses have the SAE ratings marked on the hose to assist you in selecting the correct hose. The same manufacturer must supply any replacement hydraulic hoses and fitting assemblies. As an example: Brand "X" hose and brand "Y" fitting will not normally be compatible. No "Twist" is allowed in the hydraulic hoses. "Twist" may result in premature hose failure. This can cause serious injury. Please contact Oilgear for assistance when required.

⚠ WARNING

Hydraulic cylinders can be holding a function in a certain position when the pump is off. An example of this is a function being held in the lift or partial lift position by the cylinders. If a hydraulic line is removed or the hydraulic circuits or controls are being worked on, gravity may allow the function being held in position to drop. All workers and personnel must remain clear of these areas when working on or operating the hydraulic system. Block and secure all devices and functions which apply before beginning work or operation. Failure to comply with this can result in serious injury or death.

⚠ WARNING

Any hydraulic pipe which is replaced must conform to SAE J1065 specifications. If incorrect hydraulic pipe is installed, the hydraulic system may fail, causing serious injury. Damaged or leaking fittings, pipes or hoses must be replaced before the system is returned to service.

⚠ WARNING

DO NOT heat hydraulic pipe. The carbon content of this steel tube is such that if heated for bending, and either water or air quenched, the pipe may lose its ductility and thereby be subject to failure under high pressure conditions. Serious injury can result. Damaged or leaking pipes must be replaced before the system is returned to service. Please contact Oilgear if you require assistance or have questions.

⚠ WARNING

All hydraulic pressure must be relieved from the hydraulic system prior to removing any components from the system. To relieve the hydraulic pressure from the hydraulic system, turn off the motor and operate the control panel with the key in the ON position. Failure to comply can result in serious injury. If you have any questions concerning relieving the hydraulic pressure from the system, please contact Oilgear.

WARNING

Hydraulic components can be heavy. Use caution while lifting these components. Serious personal injury can be avoided with proper handling of the components.

WARNING

Please contact Oilgear if you require assistance. When performing hydraulic test procedures, use the proper hydraulic gauges. Installing an incorrect test gauge could result in serious injury if the gauge fails. Use properly rated hydraulic hoses to allow the test gauge to be read away from moving parts and functions.

WARNING

Increasing hydraulic pressure beyond the recommendations may result in serious damage to the pump and system or serious personal injury, and may void the Oilgear Warranty. If you have questions concerning hydraulic pressures or testing procedures, please contact Oilgear before attempting the test procedures or making adjustments.

WARNING

An Oilgear pump or pump control must not be modified in any way without authorization from Oilgear. Modifications may not comply with safety standards, including ANSI safety standards, and may result in serious personal injury. Please contact Oilgear if you require assistance.

WARNING

DO NOT enter under hydraulic-supported equipment unless it is fully supported or blocked. Failure to follow this procedure can result in serious injury or death.

WARNING

Any Oilgear pump safety decals must be replaced anytime they are damaged, missing or cannot be read clearly. Failure to have proper decals in place can result in serious injury or death. (If you require safety decals, please contact Oilgear for replacement safety decals, at no charge.)

WARNING

Be sure everyone is clear of the area around the hydraulic system before operating after servicing. Remain attentive at all times when operating to check your work until you are completely sure it is safe to return to service. Failure to heed this warning may result in serious personal injury or death.

WARNING

Wear the proper protective clothing when operating, servicing or maintaining the hydraulic system or the Oilgear pump. Wear the correct protective gear, safety glasses, gloves and safety shoes. Serious injury can result without proper protective gear.

WARNING

Make sure to keep hands, feet and other parts of your body clear of revolving or moving parts. Failure to comply can cause serious injury.

WARNING

DO NOT wear watches, rings or jewelry while working with electrical and mechanical equipment. These items can be hazardous and can cause serious and painful injuries if they come into contact with electrical wires, moving parts or hydraulic equipment.

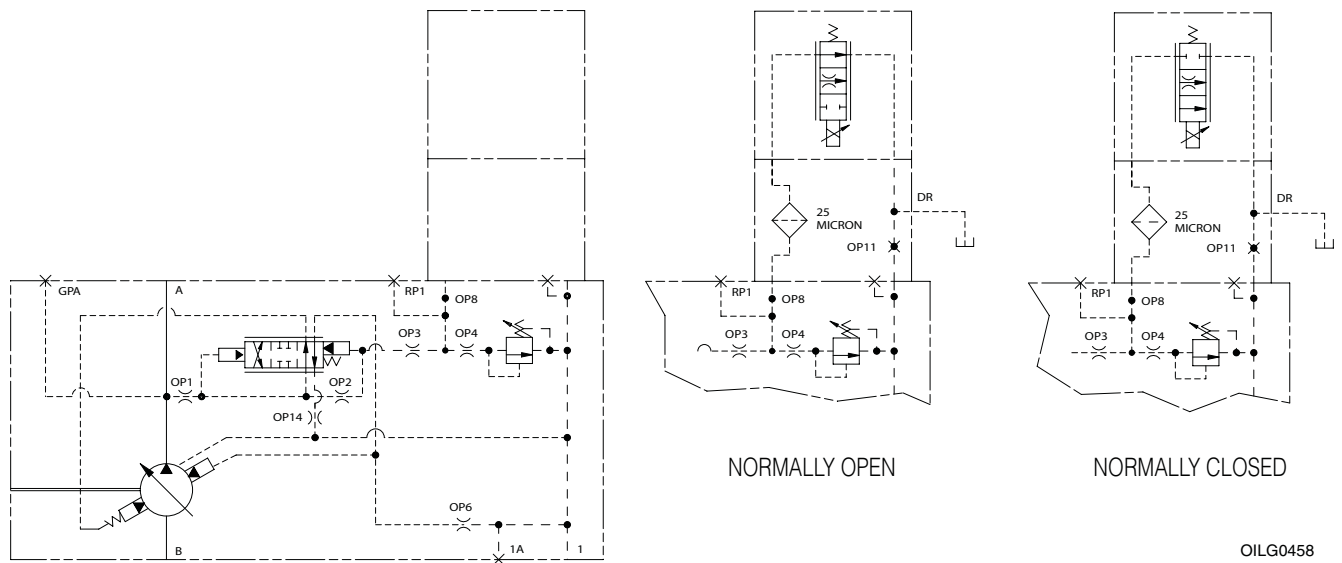

Figure 2. ASA Diagram for “P-A” or “P-B” Control Shown with Typical Pump

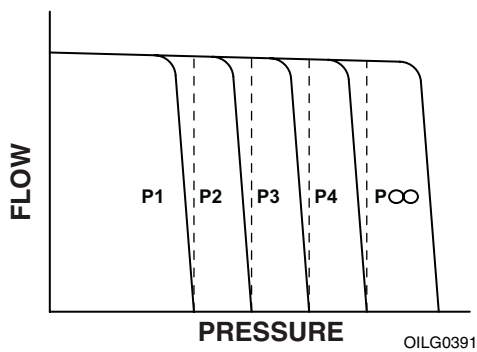

Figure 3. Curve Indicating Flow Versus Pressure for “P-A” or “P-B” Type Control

TROUBLESHOOTING

PROBLEM	CAUSES	REMEDY
Unresponsive or Unstable Control	Swashblock bearing surface and/or saddle bearings worn or damaged	Refer to 947023 Pump Service Instructions.
	Swashblock guide damaged	
	Fluid is contaminated	Inspect and clean if necessary. Refer to Filtration Recommendations Bulletin 90007.
	Contamination trapped between control piston and bore not allowing piston to move smoothly	Inspect and clean if necessary. Replace damaged parts.
	Contamination trapped between control spool and bore not allowing spool to move smoothly	
	Insufficient control flow	Increase size of control orifice "OP 6."
	Worn or damaged pilot relief seat and/or poppet	Inspect and replace if necessary.
	Faulty remote function circuit	
Hydraulic line between remote function and pump port RP1 is incorrect	Change hydraulic line.	
Insufficient Outlet Volume	Swashblock bearing surface and/or saddle bearings worn or damaged	Refer to 947023 Pump Service Instructions.
	Swashblock guide damaged	
	Low input drive speed	
	Worn cylinder barrel and/or valve plate mating surfaces	
	Failed drive shaft	
	Worn or damaged piston shoes and/or swashblock	
	Worn pistons and/or piston bores	
	Maximum volume stop adjusted incorrectly	Adjust maximum volume stop CCW to increase flow.
	Pressure compensator is set too close to operating pressure	Adjust pressure compensator CW to increase pressure.
	Control piston stuck off stroke	Inspect and replace if necessary.
Faulty remote function circuit		
Unable to Develop Full Pressure	System requires more flow than available	Check system for leaks or open functions.
	Pressure compensator adjustment not set correctly	Adjust pressure compensator CW to increase pressure.
	Contamination in control spool	Inspect and clean if necessary.
	Worn or damaged pilot relief seat and/or poppet	Inspect and replace if necessary.
	Worn or damaged proportional pressure valve	
	Control piston stuck off stroke	
Faulty remote function circuit		
Excessive Pressure	Swashblock bearing surface and/or saddle bearings worn or damaged	Refer to 947023 Pump Service Instructions.
	Swashblock guide damaged	
	Pressure compensator adjustment not set correctly	Adjust pressure compensator CCW to decrease pressure.
	Contamination in "OP 3" or "OP 4"	Inspect and clean if necessary.
	Restricted passage between outlet and control spool	Inspect and clean if necessary. Replace damaged parts.
	Contamination trapped between control piston and bore not allowing piston to move smoothly	
	Contamination trapped between control spool and bore not allowing spool to move smoothly	
	Worn or damaged proportional pressure valve	Inspect and replace if necessary.
	Proportional valve filter plugged	
Faulty remote function circuit		

GENERAL

Operation for a typical pump is described. Cut-away diagrams are a representation of typical pumps with “P-A” or “P-B” control.

Functionally, the swashblock (and resultant delivery) is positioned by two opposite (acting) control pistons. The electronic pressure control provides an infinite number of independent, remotely adjustable pressure settings in response to an electrical command.

See control parts drawing for actual configuration and location of part assemblies, orifices, connections and ports.

PRINCIPLE OF OPERATION

STARTING

The bias control piston spring positions the control and connected pump swashblock so that the pump will deliver maximum volume to raise pressure in the system.

RAISING PRESSURE (LOADING)

Pump delivery (and resultant pressure) is fed back to the control through Port "OP 1." The pressure compensating spool **(305)** is held in position by a pilot control valve spring **(328)**. Flow (and resultant pressure) is transmitted through the pressure compensating spool **(305)** to the area behind the bias control piston and through orifice Port "OP 2."

Pressure acting on either end of the pilot control valve is equal. The spool is balanced and held in the open position by the pilot control valve spring **(328)**. Flow (and resultant pressure) is also transmitted through Port "OP 3" and Port "OP 4" to the adjustable control relief (unloading) valve **(310)**, as well as Port "OP 8" to the electronic pressure compensator, which blocks further flow in the control (and pressure transmittal).

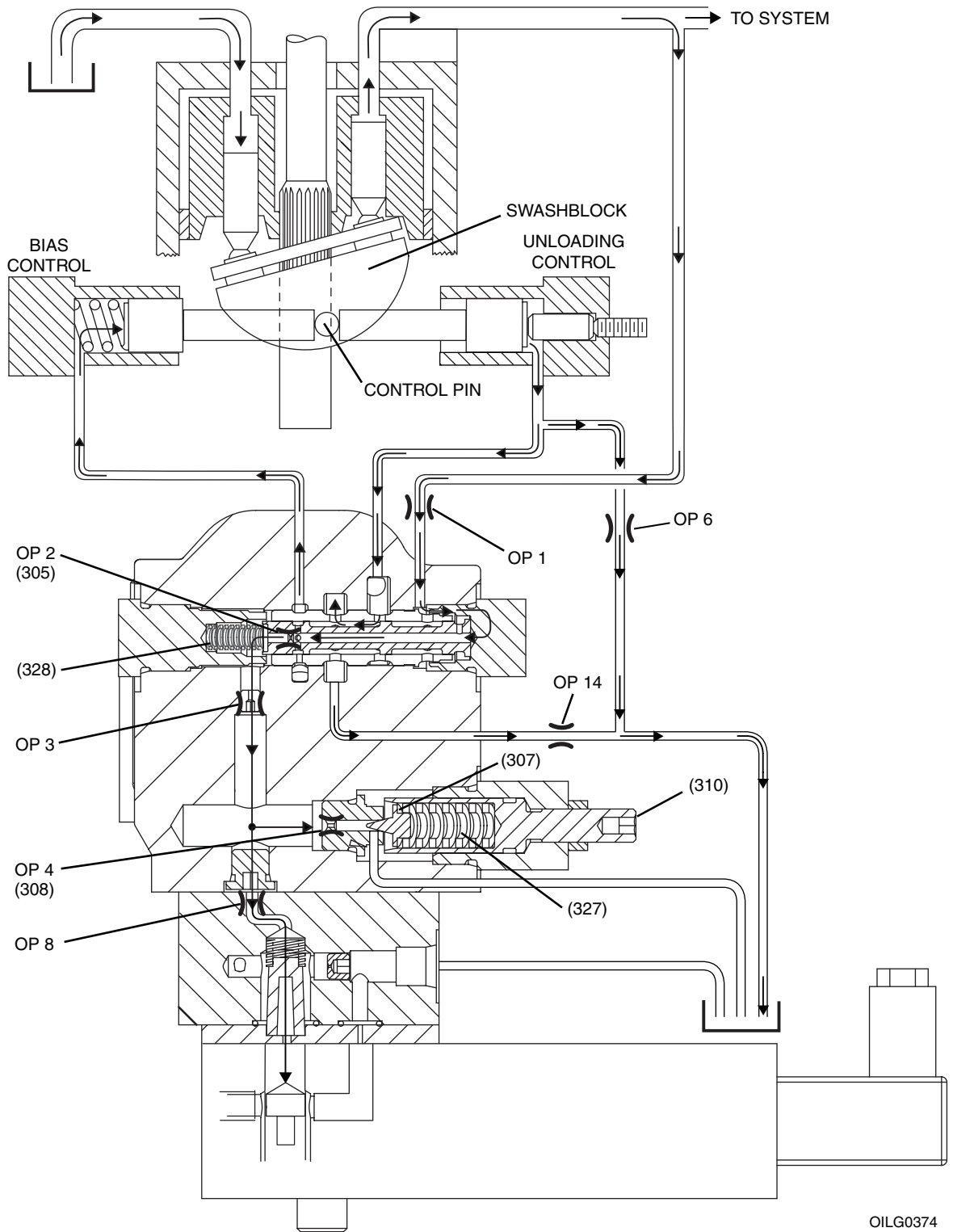

Figure 4. Raising Pressure (Loading)

COMPENSATING PRESSURE (UNLOADING) AT HIGH PRESSURE WITH ELECTRONIC PRESSURE VALVE SIGNAL TO MAXIMUM PRESSURE

When pressure on the relief valve poppet **(307)** exceeds the presetting of the relief valve screw **(310)**: Set by turning the valve screw in or out, which sets the force of the relief valve spring **(327)**. The relief valve poppet **(307)** moves off seat **(308)** and allows flow through the valve, and through drain line to pump case and case drain. Pressure is no longer acting on the spring end of the pressure compensating spool **(305)**.

Flow through "OP 2" reduces pressure on the spring end of the pressure compensating spool **(305)**. There is still pressure on the other end of the pressure compensating spool. This differential pressure forces the pressure compensating spool **(305)** to shift and compress the control valve spring **(328)**. The pressure compensating spool now allows pump delivery (and resultant pressure) to flow to the unloading control piston. The pressure compensating spool simultaneously drains the fluid from behind the bias control piston.

The control piston now moves the control pin and shifts the swashblock to a position towards neutral, where the pump delivers sufficient volume to maintain system pressure as regulated by the control relief valve **(310)**.

HOLDING PRESSURE

If the system pressure drops below preset compensating pressure, the relief valve poppet **(307)** seats and forces on the pressure compensating spool **(305)** are balanced, the pilot control valve spring **(328)** returns the spool to the original position **(Figure 4)**, swashblock position shifts, and the pump increases delivery until the relief valve screw **(310)** preset pressure is reached again.

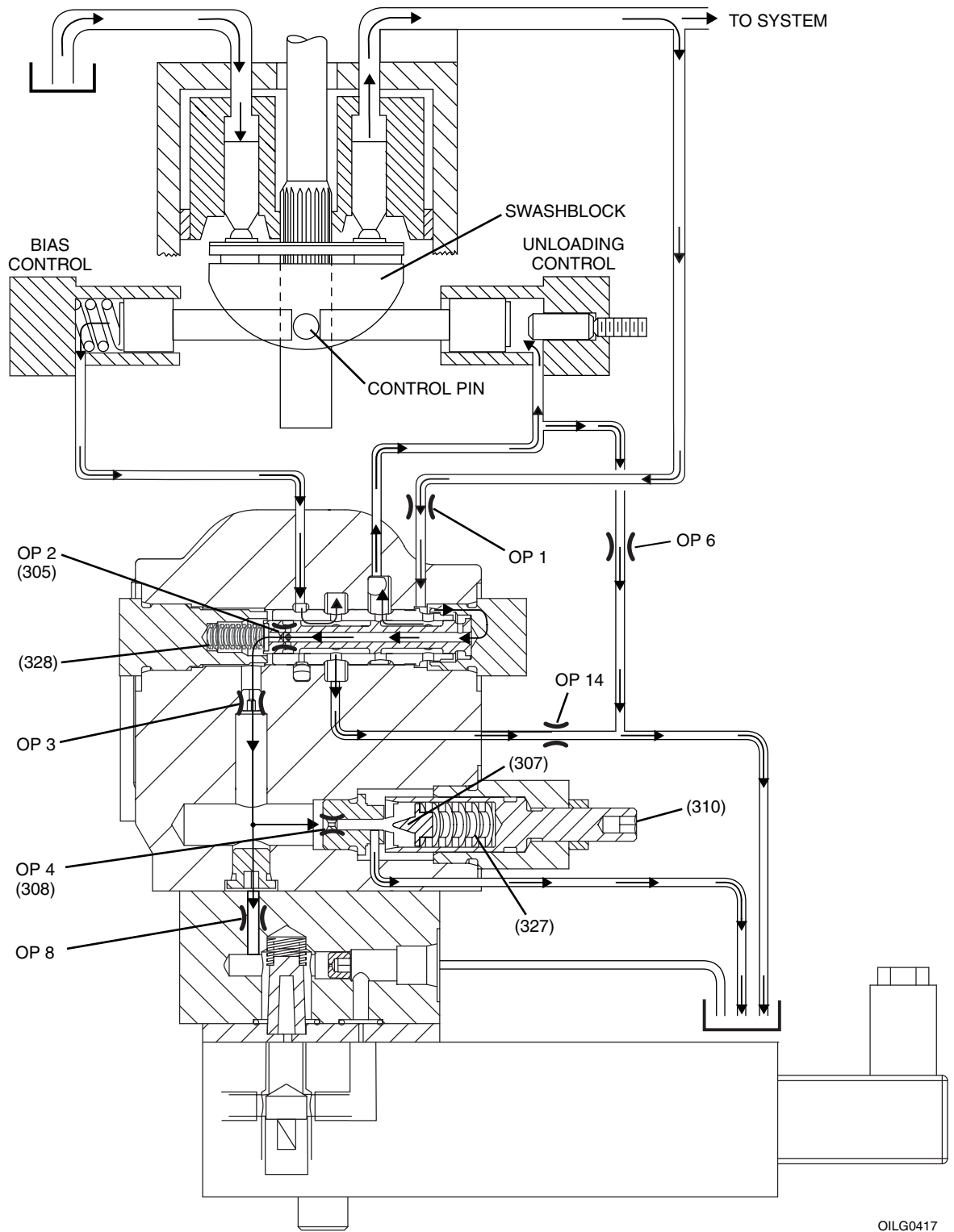

OILG0417

Figure 5. Compensating Pressure (Unloading) at High Pressure with Electronic Pressure Valve Signal to Maximum Pressure

COMPENSATING PRESSURE (UNLOADING) ELECTRONIC PRESSURE CONTROL

The electronic signal to pressure control is proportional to the pressure setting. When pressure on the pressure control valve exceeds the electronic control signal, the valve passes flow through drain line to pump case and case drain. Pressure is reduced on the spring end of the pressure compensating spool **(305)**.

Flow through “OP 2” reduces pressure on the spring end of the pressure compensating spool **(305)**. There is still full pressure on the other end of the pressure compensating spool. This differential pressure forces the pressure compensating spool **(305)** to shift and compress the control valve spring **(328)**. The pressure compensating spool now allows pump delivery (and resultant pressure) to flow to the unloading control piston. The pressure compensating spool simultaneously drains the fluid from behind the bias control piston.

The control piston now moves the control pin and shifts the swashblock to a position towards neutral, where the pump delivers sufficient volume to maintain system pressure as regulated by the electronic pressure control valve.

HOLDING PRESSURE

If the system pressure drops below the electronic signal to the control valve, pilot flow to the drain is blocked and force on the pressure compensating spool **(305)** is balanced, the pilot control valve spring **(328)** returns the spool to the original position **(Figure 4)**, swashblock position shifts, and the pump increases delivery until the electronic signal pressure is reached again.

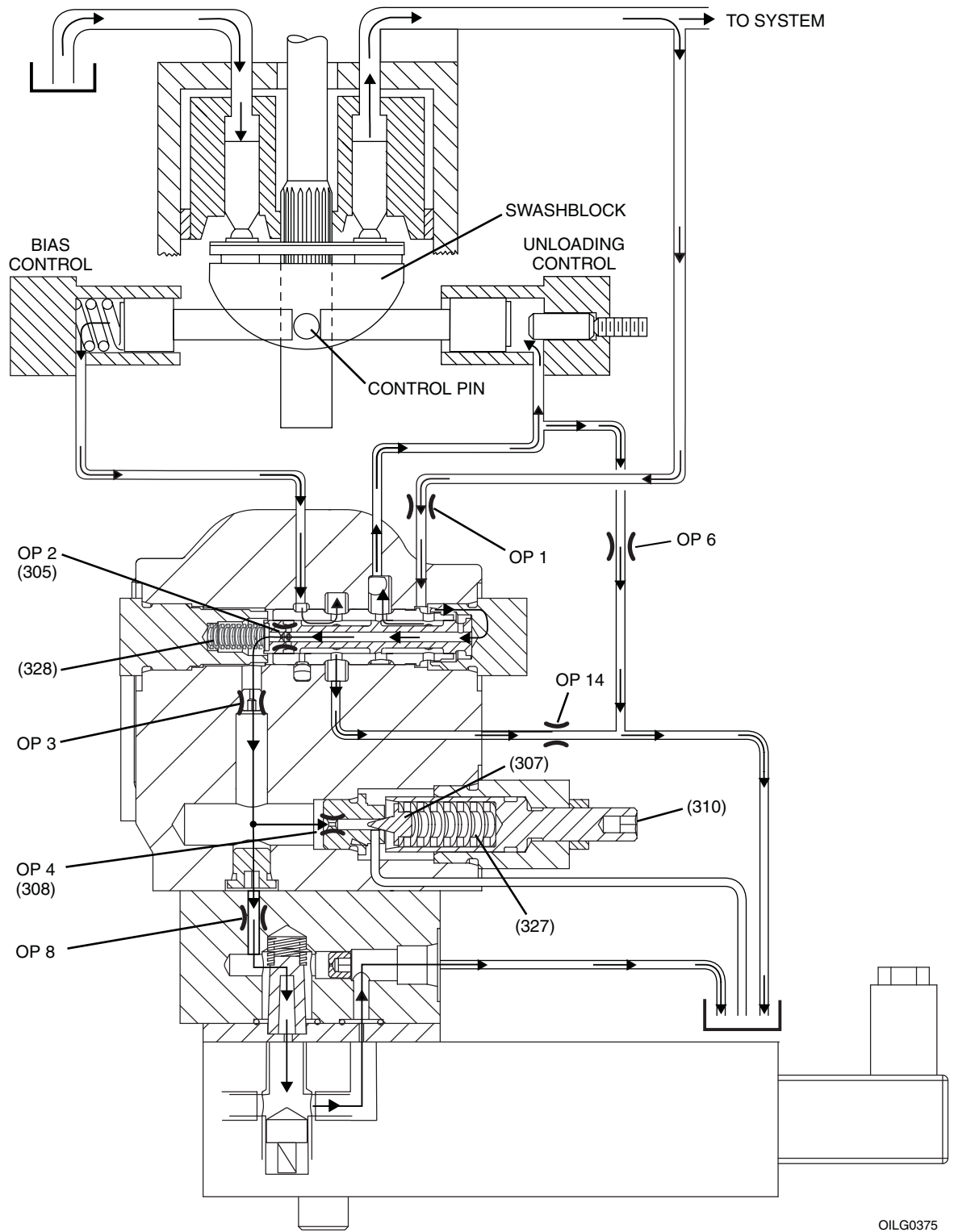

OILG0375

Figure 6. Compensating Pressure (Unloading) Electronic Pressure Control

ORIFICE FUNCTIONS

Orifice Number	Decreasing orifice diameter will result in: (increasing diameter will do the opposite)
"OP 1"	Do not decrease to less than 0.125"
"OP 2"	Do not change
"OP 3"	Do not change
"OP 4"	Do not change
"OP 6"	Decreased stability
"OP 8"	Increased stability
"OP 11"	Closed
"OP 14"	Do not change

"OP 2" Integral to spool, item 305

"OP 4" Integral to seat, item 308

"OP 8" Orifice not used (standard)

"OP 14" Integral to end cap, item 304

SCREW AND PLUG TORQUES FOR “P-A” OR “P-B” CONTROLS

Item Number	Head Type & Hex Size	Tightening Torque
306	7/8 external	50 ft•lb (68 N•m)
308	7/16 external	200 in•lb (23 N•m)
309	1 external	80 ft•lb (108 N•m)
315	1/4 internal	30 ft•lb (41 N•m)
316	3/8 internal	65 ft•lb (88 N•m)
316A	3/8 internal	65 ft•lb (88 N•m)
319	5/32 internal	48 in•lb (5 N•m)
321	3/16 internal	120 in•lb (14 N•m)
322	7/8 external	50 ft•lb (68 N•m)
323	9/16 internal	85 ft•lb (115 N•m)
325	5/32 internal	48 in•lb (5 N•m)
344	5/32 internal	48 in•lb (5 N•m)
370	5/16 internal	110 in•lb (12 N•m)
378	5/32 internal	57 in•lb (6 N•m)
379	5/32 internal	48 in•lb (5 N•m)
381	3/32 internal	20 in•lb (2 N•m)
391C	1 1/4 external	85 ft•lb (115 N•m)

PVG -048/-065/-075 B-Frame Pump “P-A” or “P-B”

CONTROL O-RING SEALS

Item Number	ARP 568 Uniform Size Number	Shore A Durometer
313	-243	70
314	-132	70
330	-013	90
331	-014	90
333	-906	90
334	-908	90
335	-910	90
336	-912	90
337	-014	*
338	-904	90
375	-012	90
376	-016	90
380	-010	90
394C	-014	90
395C	-912	90
396C	-014	*

* Teflon Backup Ring

PARTS LIST

Parts used in these assemblies are per Oilgear specifications. Use only Oilgear parts to ensure compatibility with assembly requirements. When ordering replacement parts, be sure to include pump type and serial number, and bulletin number and item number. Specify type of hydraulic fluid to ensure seal and packing compatibility.

Item	Description	Qty
301	Control Housing	1
302	Control Piston	1
303	Reduced Area Piston	1
304	End Cap	1
305	Pressure Compensator Spool	1
306	End Plug	1
307	Poppet	1
308	Seat	1
309	Bonnet	1
310	Adjusting Screw	1
311	Control Pin	1
312	Shim	4
313	O-ring	1
314	O-ring	1
315	Screw	3
316	Screw	1
316A	Screw	2
318	Jam Nut	1
319	Orifice	1
321	SAE #4 Plug	2
322	Filter End Plug	1
323	SAE #12 Plug	1
325	Orifice	1
327	Spring	1
328	Spring	1
329	Spring	1
330	O-ring	3

Item	Description	Qty
331	O-ring	1
333	O-ring	1
334	O-ring	2
335	O-ring	1
336	O-ring	1
337	Backup Ring	1
338	O-ring	2
344	Orifice	1
348	Roll Pin	2
370	P2C Controller	1
371	P2C Block	1
372	Spring	1
373	Fuse Filter	1
375	O-ring	1
376	O-ring	1
377	Seal Plate	1
378	Screw	4
379	Plug	1
380	O-ring	3
381	Screw	1
391C	Maximum Stop Bonnet	1
392C	Maximum Stop Adjusting Screw	1
393C	Jam Nut	1
394C	O-ring	1
395C	O-ring	1
396C	Backup Ring	1

PVG -048/-065/-075 B-Frame Pump “P-A” or “P-B”

PVG B P-A/BNNNN Control Service Kits

Reference: 517467-200 Ass'y Drwg

Document Number: 517467-SK

Revision: 0 (8-28-09)

Sheet 1 of 1

Description	Kit No.	Design Series	Items Included (quantity is 1 unless noted)
Control Pistons/Spring			
All	L723987-002	All	302, 303, 329
Pressure Compensator Relief			
Viton Seals	L723987-101	All	307, 308, 312(4), 327, 333
Pressure Compensator Spool			
All	L723987-201	All	305, 328
Pressure Compensator Adjuster			
Viton Seals	L300574HS07	All	309, 310, 318, 331, 335, 337
Maximum Volume Stop			
Viton Seals	L516319-001	All	391C, 392C, 393C, 394C, 395C, 396C
Filter Element			
All	200298HS25	All	373
Proportional Relief			
Normally Open			370
Viton Seals	L247579-001	All	
Normally Closed			
Viton Seals	L247579-002	All	
Control Seal Kit			
Viton Seals	K517467-001	All	313, 314, 330(3), 331, 333(2), 334(2), 335, 336, 337, 338(2), 375, 376, 380(3), 394C, 395C, 396C
End Cap Assembly			
Viton Seals	L517108-319	F1(A)	303, 304, 305, 306, 307, 308, 309, 310, 312(4), 314, 315(3), 318, 320, 321, 322, 325, 326, 326A, 327, 328, 331, 332, 333, 334(2), 335, 337, 338(2), 339, 343, 344, 348(2)
Proportional Relief Module			
Normally Open			370, 371, 372, 373, 375, 376, 377, 378(4), 379, 380(3), 381
Viton Seals	L723004-003	All	
Normally Closed			
Viton Seals	L723004-005	All	
(A) End cap must match control housing, control housing must match pump housing A1, B1, B2 end caps fit A1, B1, B2 control housings A1, B1, B2 pressure compensator spool fits A1, B1, B2 control housings A1, B1, B2 control piston fits A1, B1, B2 control housings A1, B1, B2 control housings fit A1, B1, B2 pump housings F1 series end caps fit F1 series control housings F1 pressure compensator spool fits F1 control housings F1 control piston fits F1 control housings F1 control housings fit F1 pump housings			

PVG -048/-065/-075 B-Frame Pump "P-A" or "P-B"

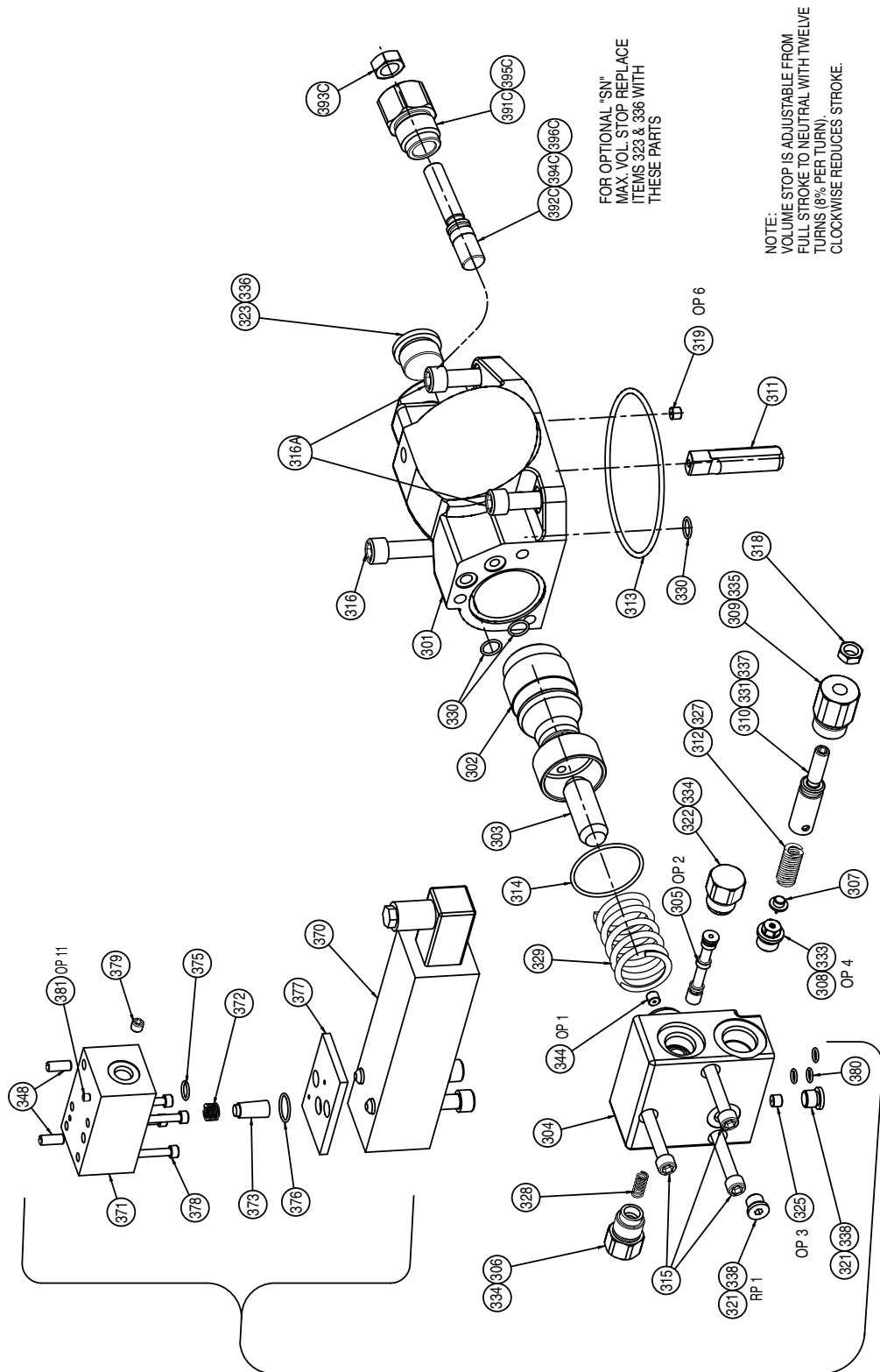

Figure 7. Exploded Parts Drawing for "P-A" or "P-B" Electronic Pressure Compensator, Series F1U Control (517467-200 sheet 2)

OILG0460

PVG -048/-065/-075 B-Frame Pump "P-A" or "P-B"

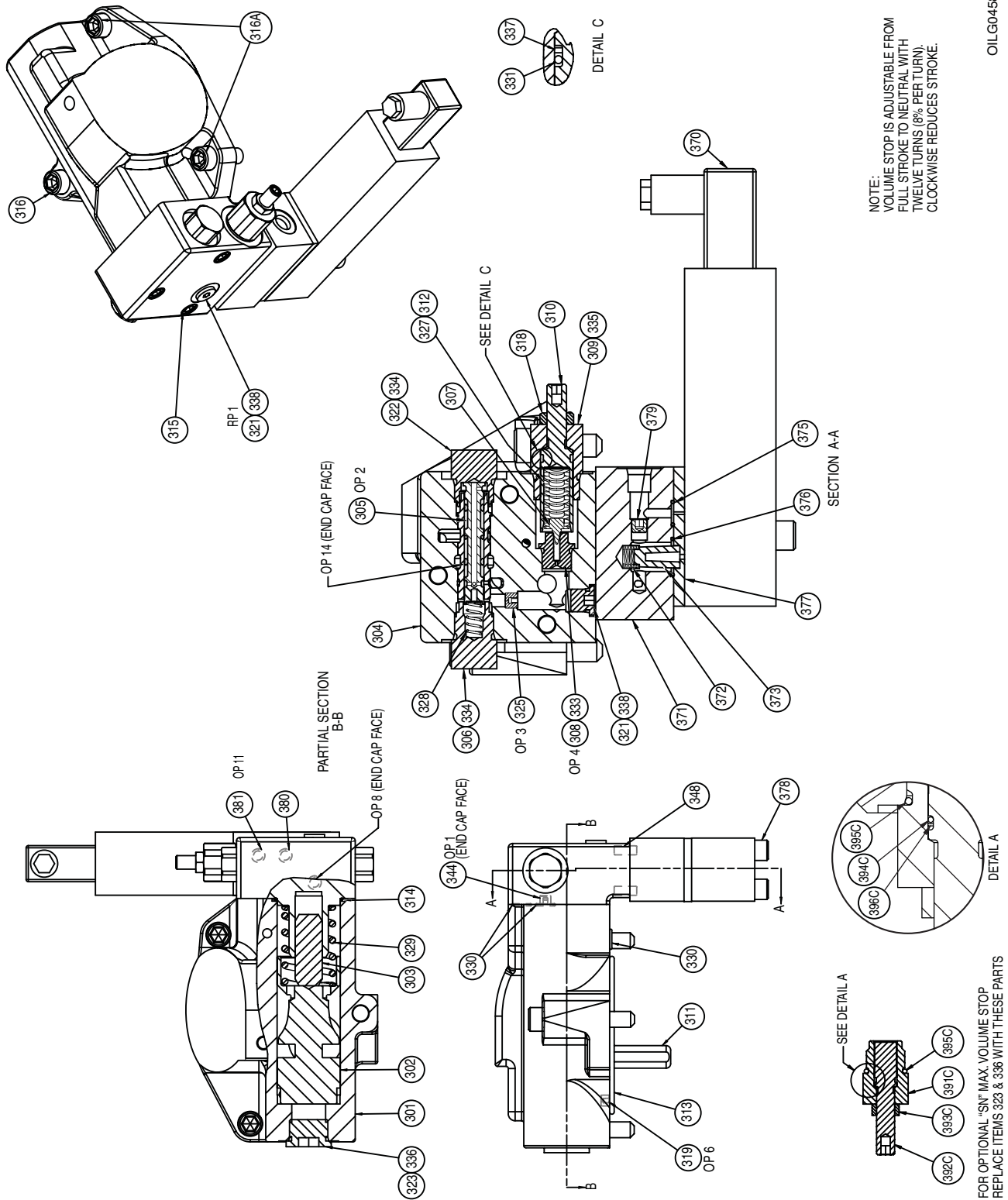

Figure 8. Cross Section Parts Drawing for "P-A" or "P-B" Electronic Pressure Compensator, Series F1U Control (517467-200 sheet 1)

AFTER SALES SERVICES

At Oilgear we build products to last. It is the nature of this type of machinery to require proper maintenance regardless of the care we put into manufacturing. Oilgear has several service programs in place to help you.

STAY-ON-STREAM SERVICE

By signing up for Oilgear's Stay-On-Stream program, you can prepare for problems before they happen. Certain field tests such as fluid testing, slip testing and electronic profile recording comparisons can be performed by our field service people or your own factory trained personnel. These tests can indicate problems before they become "down-time" difficulties.

SERVICE SCHOOLS

Oilgear conducts training to train your maintenance personnel. "General" hydraulic or electronic training is conducted at our Milwaukee, Wisconsin plant on a regular basis. "Custom" training, specifically addressing your particular hydraulic and electro-hydraulic equipment, can be conducted at your facilities.

SPARE PARTS AVAILABILITY

Prepare for your future needs by stocking Oilgear original factory parts. Having the correct parts and necessary skills "in-plant" enables you to minimize "down-time." Oilgear has developed parts kits to cover likely future needs. Oilgear Field Service Technicians are also ready to assist you and your maintenance people in troubleshooting and repairing equipment.



THE OILGEAR COMPANY
2300 South 51st Street
Milwaukee, Wisconsin 53219
www.oilgear.com