

HYDRAULIC CIRCUIT

NOTES:

1. PUMPS DESIGNED FOR ONE-WAY SERVICE AND ARE DIMENSIONED AS SHOWN.
2. THESE UNITS ARE DESIGNED TO RUN CASE FULL OF FLUID AT ALL TIMES. FILL CASE BEFORE STARTING AND CONNECT DRAIN LINES ACCORDINGLY.
3. NUMERICAL DIMENSIONS GIVEN IN INCHES/[MM].
4. NET WEIGHT- 171 LBS [78 KG] FOR VERSION SHOWN
185 LBS [84 KG] FOR THRU SHAFT VERSION.

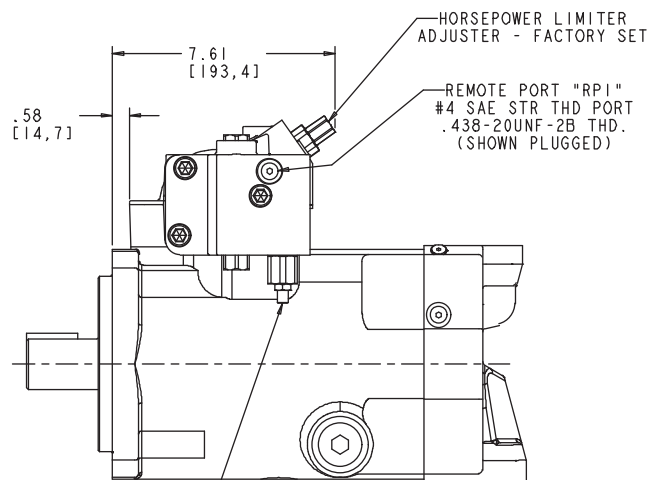
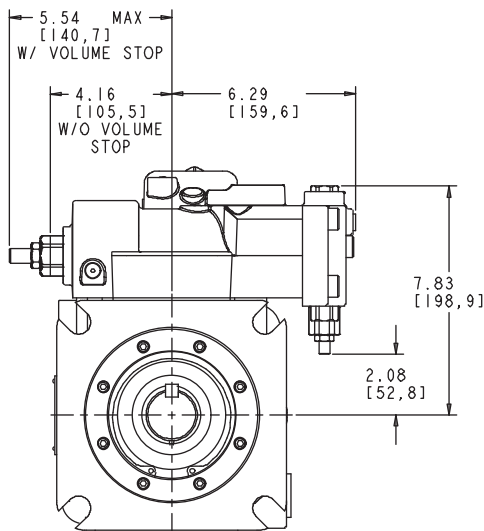
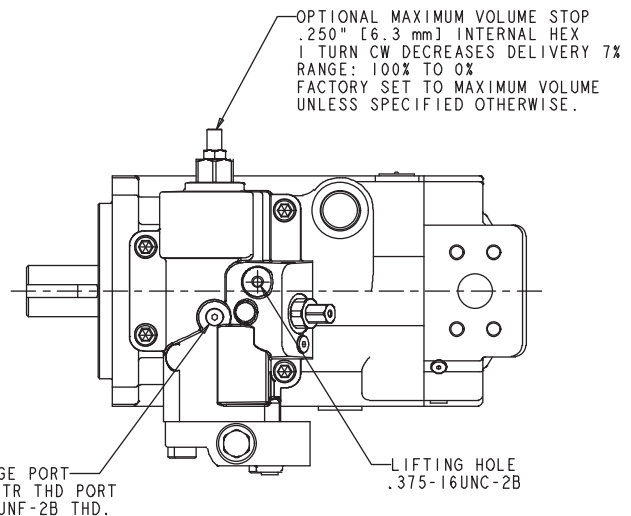
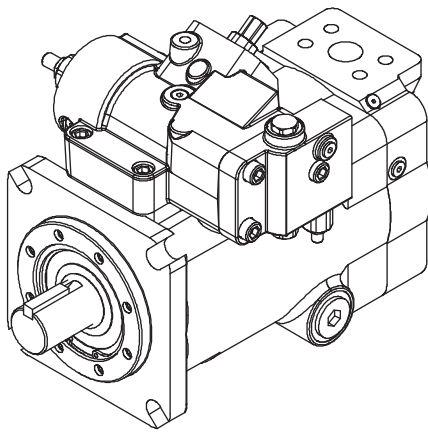

PRESSURE COMPENSATOR ADJUSTMENT
.188" [4.8 mm] INTERNAL HEX
1 TURN CW INCREASES PRESSURE SETTING 1000 PSI.
RANGE: 300 TO 5000 PSI
FACTORY SET AT MINIMUM UNLESS SPECIFIED OTHERWISE.