

Oilgear

PFBA, PFBK, PFCM, PFCS
High Pressure Pumps

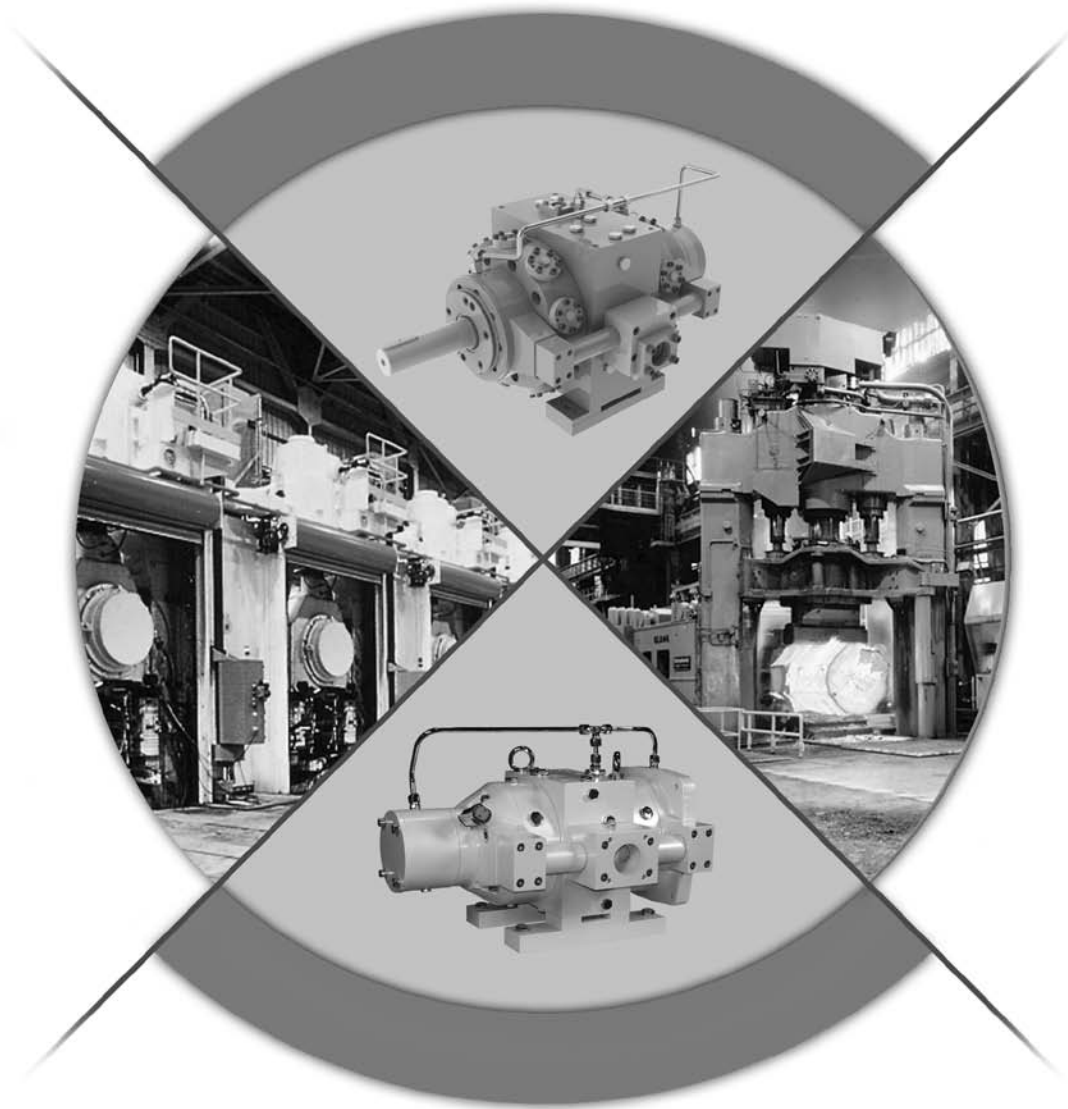

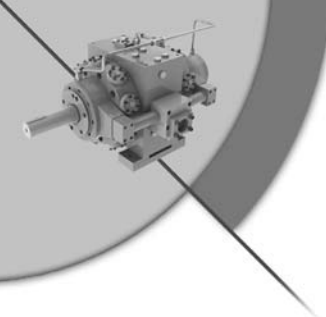

Table of Contents

Performance Assurance	page 3
Features and Benefits	4
PFBA	
Features and Benefits	5
Specifications	6
Performance Data	7
Ordering Information	9
PFBK	
Features and Benefits	10
Specifications	11
Performance Data	12
Ordering Information	14
PFCM	
Features and Benefits	15
Specifications	16
Performance Data	17
Ordering Information	19
PFCS	
Features and Benefits	20
Specifications	21
Performance Data	22
Ordering Information	23

PERFORMANCE ASSURANCE — STANDARD WITH EVERY OILGEAR COMPONENT



Oilgear
PERFORMANCE
ASSURANCE

Every Oilgear product is shipped to you with our Performance Assurance — a corporate commitment to stay with your installation until our equipment performs as specified.

Hydraulic equipment and systems have been Oilgear's primary business since 1921. For decades, we have developed hydraulic techniques to meet the unique needs and unusual fluid power problems of machinery builders and users worldwide, matching fluid power systems to a tremendous range of applications and industries. Our exclusive Performance Assurance program is built upon that strong foundation.

As a customer, you also benefit from access to Oilgear's impressive technical support network. You'll find factory trained and field-experienced application engineers on staff at every Oilgear facility. They are backed by headquarters staff who can access the records and knowledge learned from decades of solving the most difficult hydraulic challenges.

When your design or purchase is complete, our service is just beginning. If you ever need us, our Oilgear engineers will be there, ready to help you with the education, field service, parts and repairs to assure that your installation runs smoothly—and keeps right on running.



Oilgear Performance

PUMPS WITH MULTIPLE FIXED DELIVERIES FOR HIGH PRESSURE (OIL OR 95/5 HWCF) HEAVY DUTY APPLICATIONS

Internationally known as a world class hydraulic company, Oilgear specializes in the design, engineering technology and equipment needed to solve tough hydraulic problems by combining the right pump and components into an engineered system that will meet specific needs.

Four of Oilgear's long line of pumps are included in this brochure. They were designed for applications that require the following:

- **HIGH PRESSURE**
Up to 14500 psi (1000 bar) with most hydraulic fluids (5000 psi (345 bar) with 95/5).
- **HEAVY DUTY CONSTRUCTION**
Many of these units have operated 40,000 hours before inspection and reconditioning is necessary.
- **HIGH DIRT TOLERANCE**
Check valve design provides a high degree of contamination resistance.
- **OPERATION ON LOW VISCOSITY and SPECIAL FLUIDS INCLUDING 95/5**
These pumps are designed with hydrostatic type bearings and a stationary cylinder.
- **MULTIPLE DELIVERIES** – Up to three separate displacements available from a single pump.



PFBA

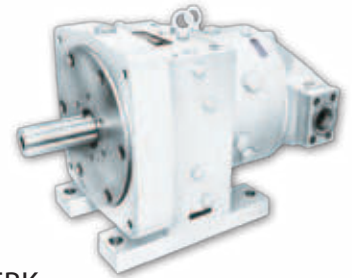

PFBK

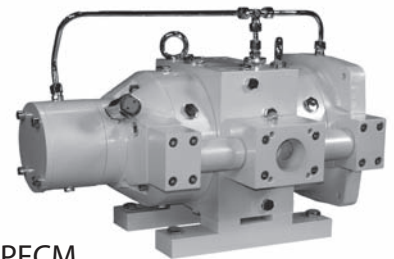

PFCM

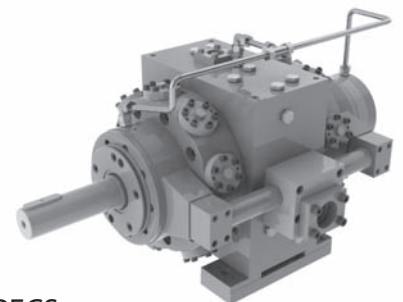

PFCS

PFBA

HIGH PRESSURE AXIAL PISTON PUMPS

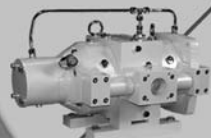

Oilgear Features and Benefits

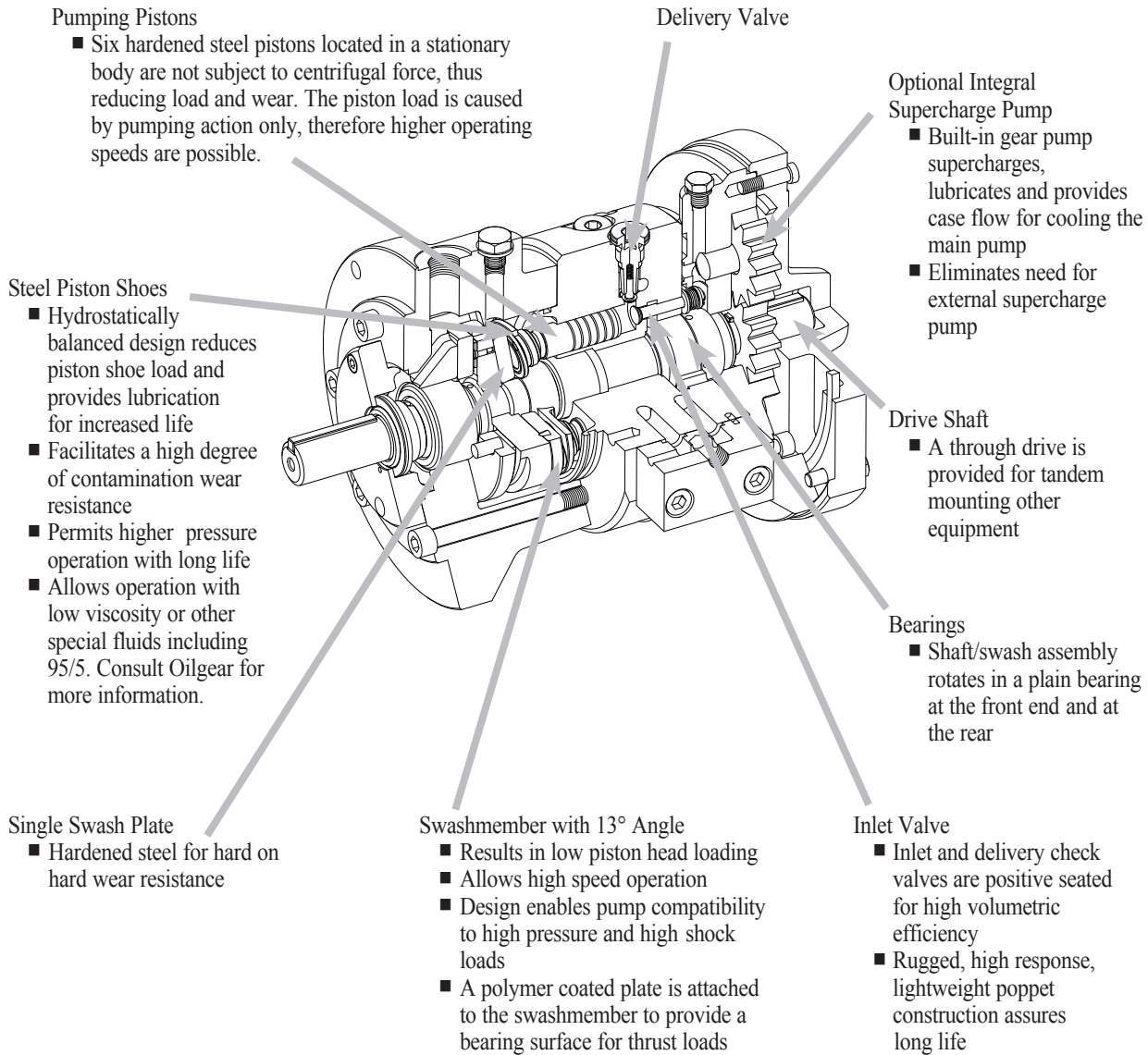

These axial piston pumps are used in a wide variety of applications, including die casting and injection molding machines, high pressure test rigs, civil and marine projects, intensifier systems, extrusion presses, forging presses and high pressure forced lubrication systems for long turbines as well as metal forming machines.

The "PFBA" Pump has proved itself successful for use with high water content and low viscosity fluids.

If using these fluids, please consult Oilgear for more information.

SINGLE DISCHARGE PFBA

UNIT	THEORETICAL DISPLACEMENT		RATED CONTINUOUS PRESSURE		DRIVE SPEED (flow and input power at rated pressure)											
					1200 rpm		1500 rpm		1800 rpm							
	in. ³ /rev.	ml/rev.	psi	bar	FLOW RATE		INPUT		FLOW RATE		INPUT		FLOW RATE		INPUT	
02	0.183	3	14500	1000	0.87	3,3	10.8	8,0	1.09	4,1	13.5	10,1	1.30	4,9	16.2	12,1
2	0.275	4,5			1.30	4,9	16.2	12,1	1.63	6,2	20.2	15,1	1.96	7,4	24.3	18,1
2/2	0.549	9			2.61	9,9	32.4	24,2	3.26	12,3	40.5	30,2	3.91	14,8	48.6	36,2
4	0.564	9,25			2.75	10,4	33.1	24,7	3.44	13,0	41.4	30,9	4.12	15,6	49.7	37,1
6	0.839	13,75	10150	700	4.12	15,6	30.6	22,8	5.15	19,5	38.2	28,5	6.17	23,4	45.9	34,2
8	1.129	18,5	8700	500	5.71	21,6	32.2	24,0	7.14	27,0	40.2	30,0	8.56	32,4	48.3	36,0

MULTIPLE DISCHARGE PFBA

UNIT	NUMBER OF DISCHARGES	DISCHARGE #	THEORETICAL DISPLACEMENT		RATED DRIVE SPEED					
					1200 rpm		1500 rpm		1800 rpm	
			in. ³ /rev.	ml/rev.	USgpm	lpm	USgpm	lpm	USgpm	lpm
2/2	2	1	0.275	4,5	1.30	4,9	1.63	6,2	1.96	7,4
		2	0.275	4,5	1.30	4,9	1.63	6,2	1.96	7,4
6	2	1	0.275	4,5	1.30	4,9	1.63	6,2	1.96	7,4
		2	0.564	9,25	2.75	10,4	3.44	13,0	4.12	15,6
8	2	1	0.564	9,25	2.75	10,4	3.44	13,0	4.12	15,6
		2	0.564	9,25	2.75	10,4	3.44	13,0	4.12	15,6

DIMENSIONS*

UNIT	L LENGTH		W WIDTH		H HEIGHT		WEIGHT	
	in.	mm	in.	mm	in.	mm	lb.	kg
02	13.6	346	8.3	211	8.3	211	99	45
2								
2/2								
4								
6								
8								

*All dimensions are approximate. For detailed information consult your factory representative.





Oilgear Performance Data

PFBA2

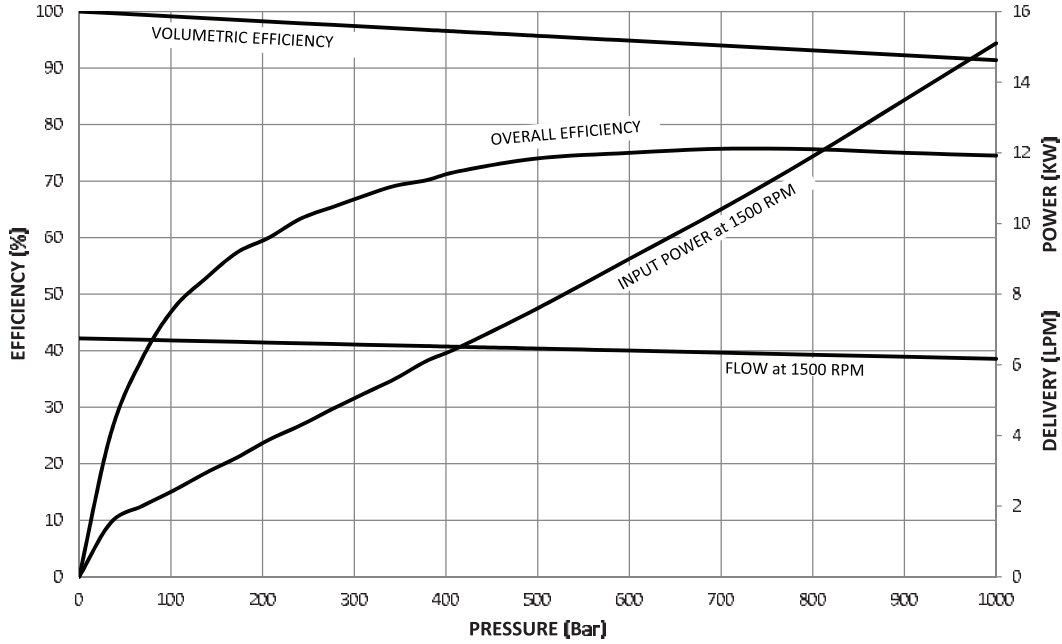

PFBA4

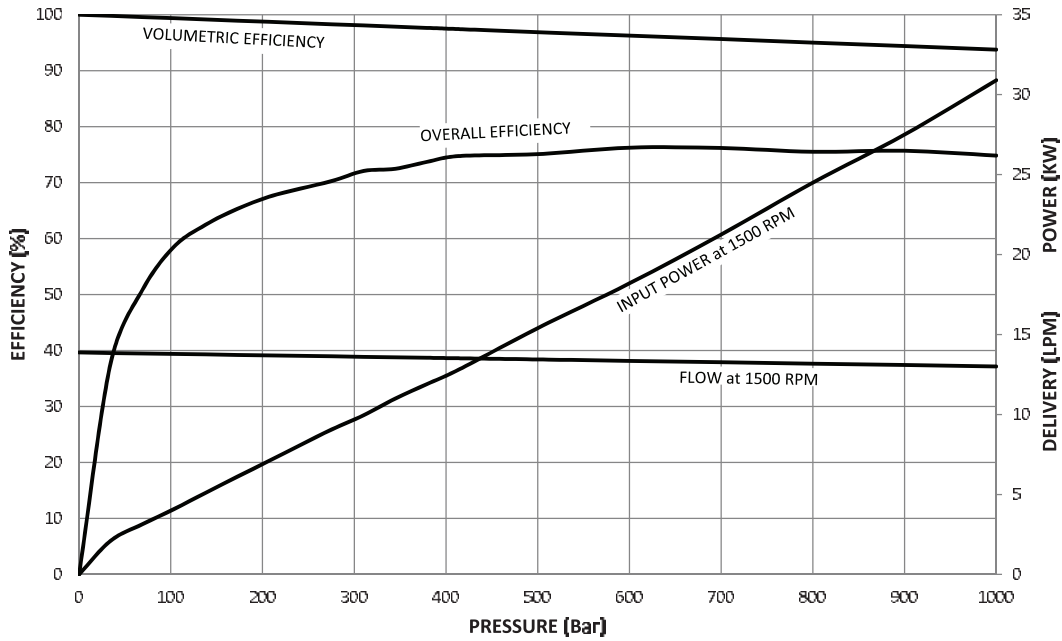

Oilgear Performance Data

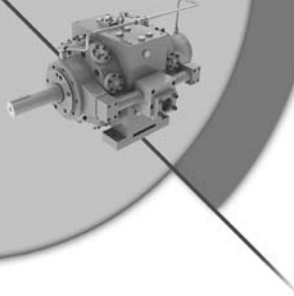

■ PFBA6

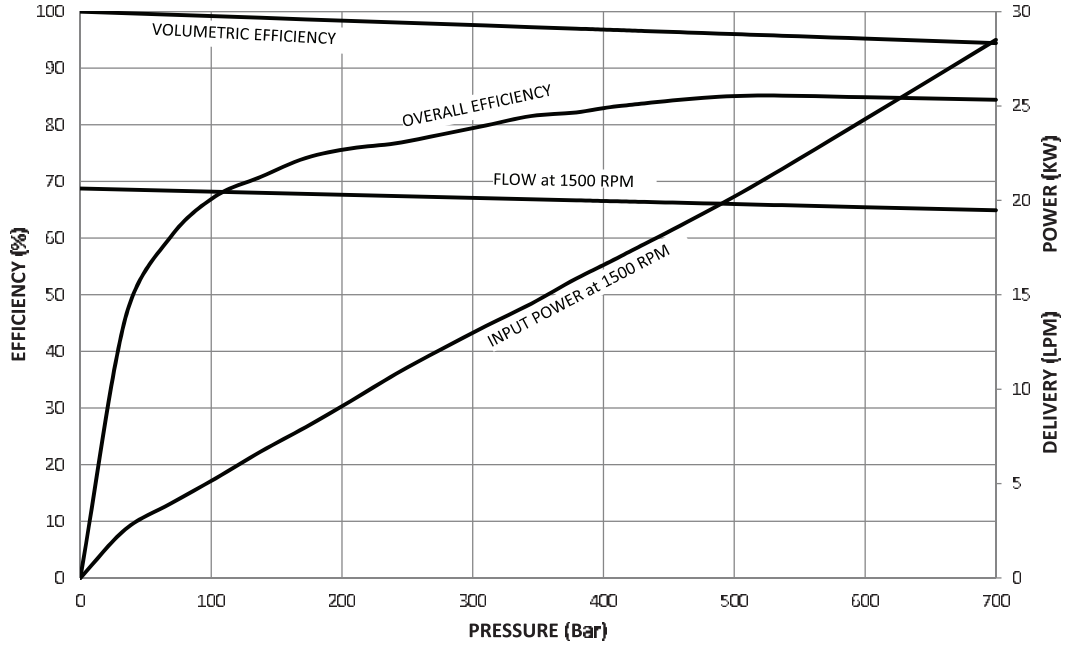

■ PFBA8

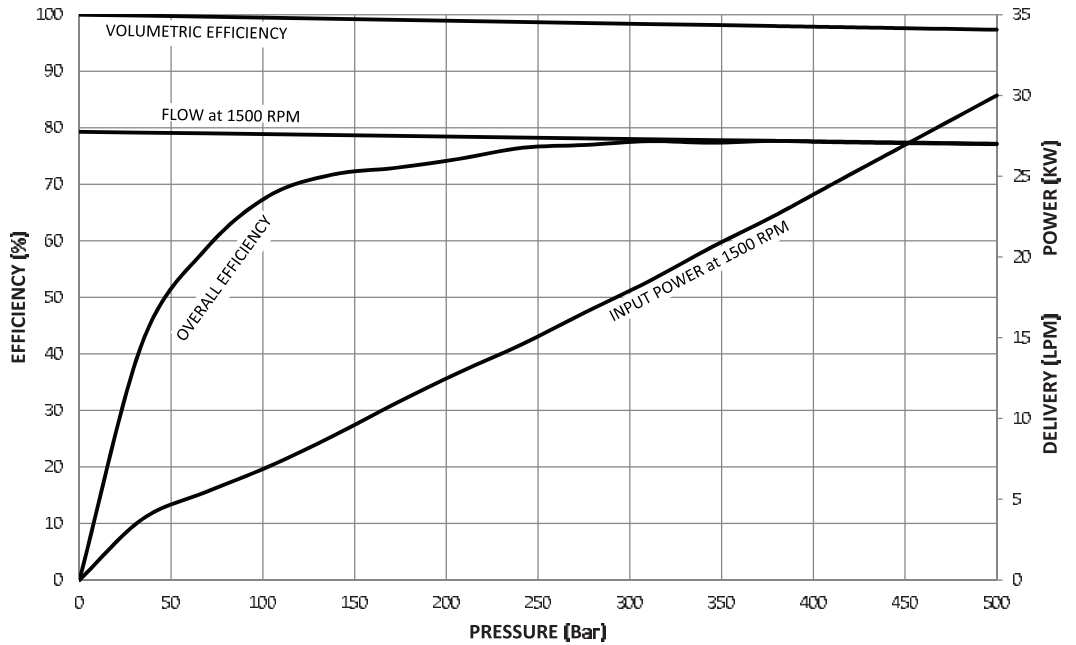

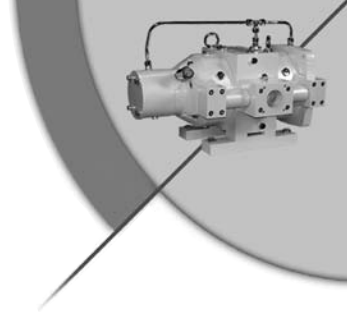

HOW TO ORDER – PFBA

BLOCK NUMBER EXPLANATION	1	2	3	4	5	6	7	8	9	10	11	12	13	14	15	16	17
HIGH PRESSURE PUMP EXAMPLE	P	F	B	A	B	4--	A	*	B	A	R	S	L	R	I	B	A

- | | |
|---|--|
| <p>1 = UNIT
P = Pump</p> <p>2 = TYPE
F = Fixed</p> <p>3 = DESIGN
B = High Pressure Single Swash</p> <p>4 = FRAME
A = Up to 32 ml/Rev</p> <p>5 = STYLE
A = Separate Boost
B = Internal Boost (32 - 100 cSt)</p> <p>6 = DISPLACEMENT
02- = 3 ml/Rev
2-- = 4.5 ml/Rev
2/2 = 9 ml/Rev
4-- = 9.25 ml/Rev
6-- = 13.75 ml/Rev
8-- = 18.5 ml/Rev</p> <p>7 = DESIGN SERIES
A = Standard for Oil</p> <p>8 = MODIFIER
* = Assigned by Factory</p> <p>9 = DIMENSIONS
B = Metric with BSP Ports</p> <p>10 = WORKING PRESSURE
A = 1000 Bar (Up to Size 4--)
7 = 700 Bar (Size 6--)
6 = 600 Bar (Size 8--)</p> | <p>11 = ROTATION (Viewed from Drive Shaft End)
L = Counterclockwise (CCW) Left Hand
R = Clockwise (CW) Right Hand</p> <p>12 = MOUNTING
S = Standard Face Mount
F = Foot</p> <p>13 = INLET POSITION (Viewed from Drive Shaft End)
L = Left
R = Right</p> <p>14 = DISCHARGE POSITION (Viewed from Drive Shaft End)
L = Left
R = Right</p> <p>15 = SHAFT
I = Keyway</p> <p>16 = SEALS
B = Buna N (Nitrile)
E = E.P.D.M.
V = Viton
Z = Special (Available on Request)</p> <p>17 = END / REAR MOUNT
A = SAE 'A' Frame
B = SAE 'B' Frame
C = Closed End
F = Tandem FBA
J = H or J Vane V20
K = K Vane 20V, 25V</p> |
|---|--|



PFBK

HIGH PRESSURE AXIAL PISTON PUMPS

Oilgear Features and Benefits

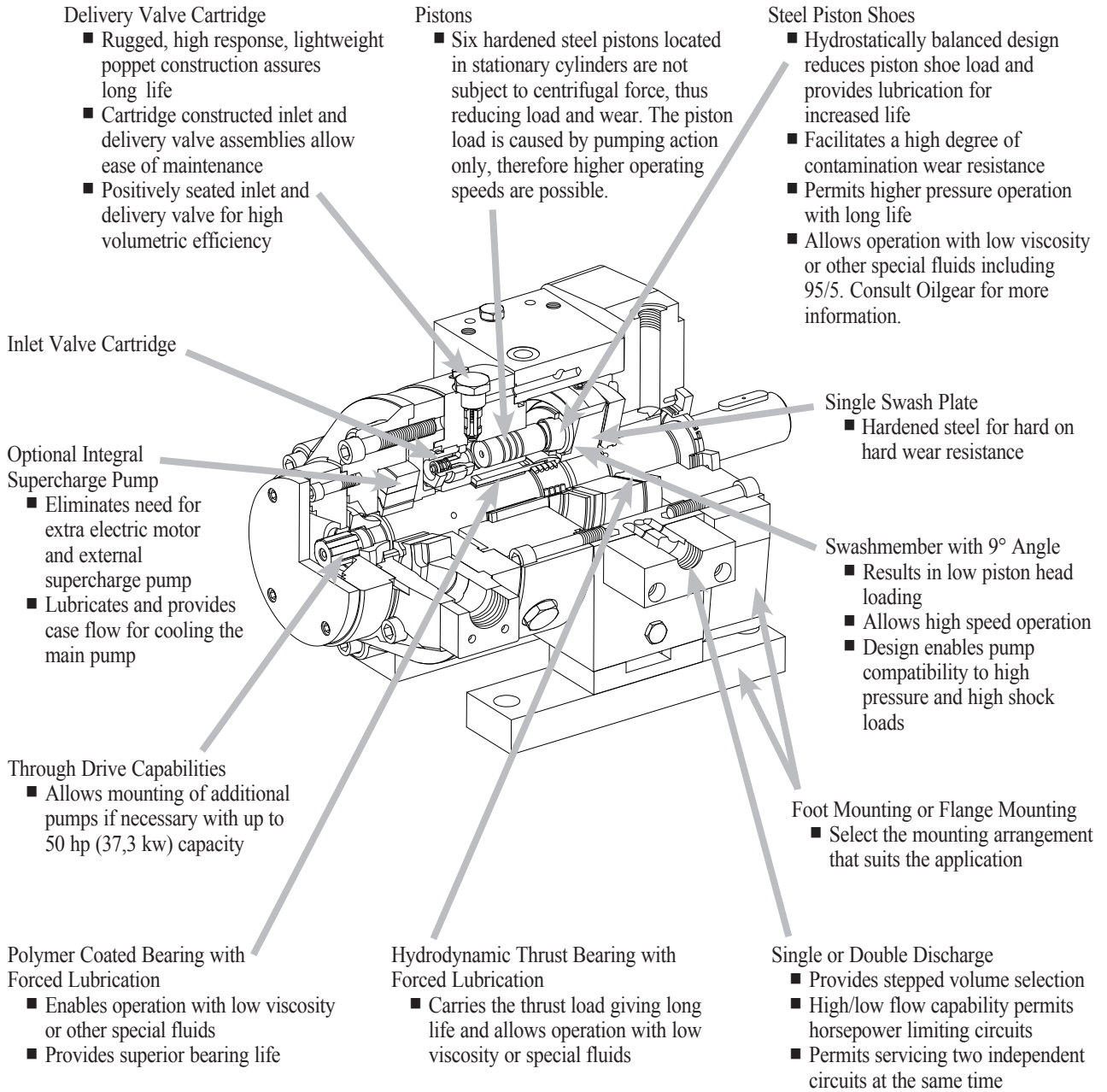

High Pressure

Up to 14500 psi (1000 bar) with most hydraulic fluids – 5000 psi (345 bar) with 95/5. Consult Oilgear for more information.

Heavy-Duty Construction

Many of these units have operated over 40,000 hours before inspection and reconditioning is necessary.

Wide Variety of Applications

High pressure test rigs, civil and marine projects, intensifier systems, extrusion and forging pressure and other heavy duty metal forming machines.

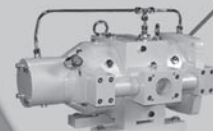

SINGLE DISCHARGE PFBK

UNIT	THEORETICAL DISPLACEMENT		RATED CONTINUOUS PRESSURE		RATED DRIVE SPEED											
					1200 rpm*				1500 rpm*				1800 rpm*			
					INPUT		INPUT		INPUT		INPUT					
	in. ³ /rev.	ml/rev.	psi	bar	USgpm	lpm	hp	kw	USgpm	lpm	hp	kw	USgpm	lpm	hp	kw
WITH INTEGRAL SUPERCHARGE																
PFBK033	2.13	34.9	14500	1000	9.6	36,4	111.0	82.8	12.0	45,5	138.0	103.0	14.4	54,6	166.0	124.0
PFBK043	2.73	44.7	10000	700	12.7	48,3	92.6	69,1	15.9	60,4	116.0	86,6	19.1	72,5	139.0	104.0
PFBK052	3.33	54.5	10000	700	15.5	58,9	109.0	81,3	19.4	73,6	136.4	101,8	23.3	88,4	163.8	122,2
PFBK065	4.17	68.4	6000	415	19.5	73,9	84.3	62,9	24.4	92,4	105.0	78,4	29.3	110,9	127.0	94,5

Note: With external supercharge, 80-to-100 psi (5,5-to-6,9 bar) is required.

*At rated pressure.

DOUBLE DISCHARGE PFBK

UNIT	DISCHARGE #	DRIVE SPEED					
		1200 rpm*		1500 rpm*		1800 rpm*	
		USgpm	lpm	USgpm	lpm	USgpm	lpm
PFBK033	1	5.0	18,9	6.2	23,6	7.5	28,3
	2	5.0	18,9	6.2	23,6	7.5	28,3
PFBK043	1	5.0	18,9	6.2	23,6	7.5	28,3
	2	7.8	29,4	9.7	36,8	11.7	44,2
PFBK052	1	7.8	29,4	9.7	36,8	11.7	44,2
	2	7.8	29,4	9.7	36,8	11.7	44,2
PFBK065	1	9.8	37,0	12.2	46,2	14.6	55,5
	2	9.8	37,0	12.2	46,2	14.6	55,5

*At rated pressure.

DIMENSIONS (With Discharge Block*)

UNIT	L LENGTH**		W WIDTH		H HEIGHT		WEIGHT			
							FOOT MOUNT		FLANGE MOUNT	
	in.	mm	in.	mm	in.	mm	lb.	kg	lb.	kg
PFBK033	23.3	593	14.4	366	14.1	359	462	210	423	192
PFBK043										
PFBK052										
PFBK065										

* All dimensions are approximate. For detailed information consult your factory representative.

** Length without integral supercharge = 22.3 in. (566 mm).

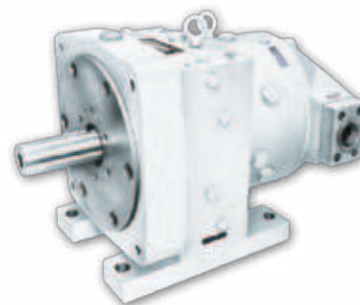



Oilgear Performance Data

■ PFBK033

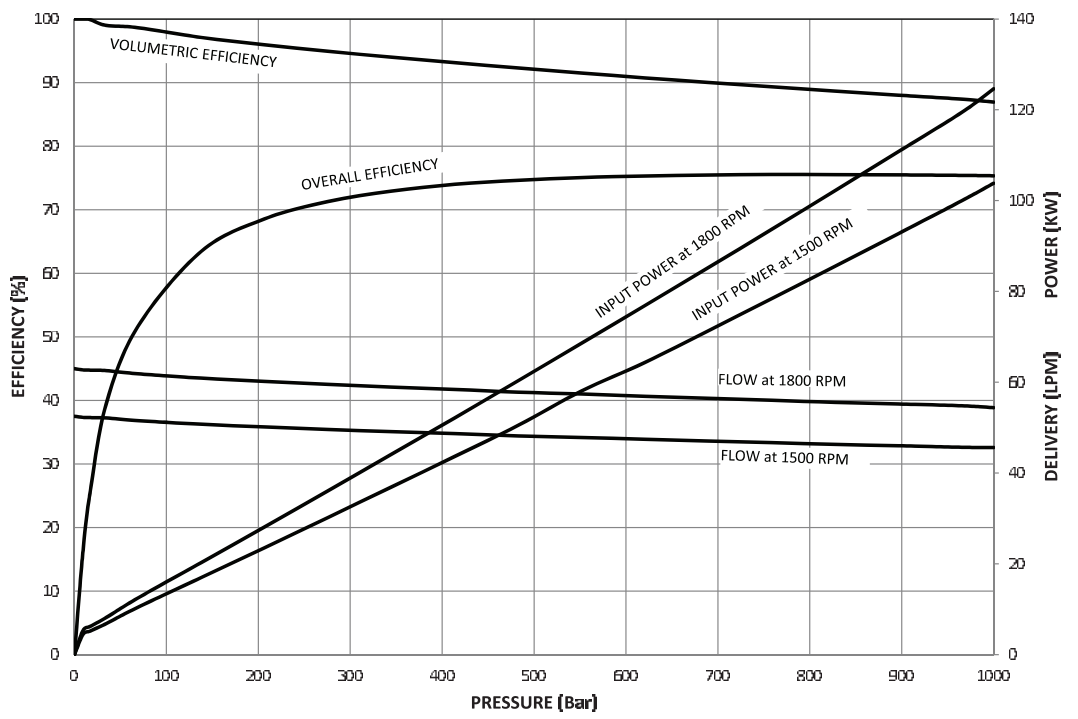

■ PFBK043

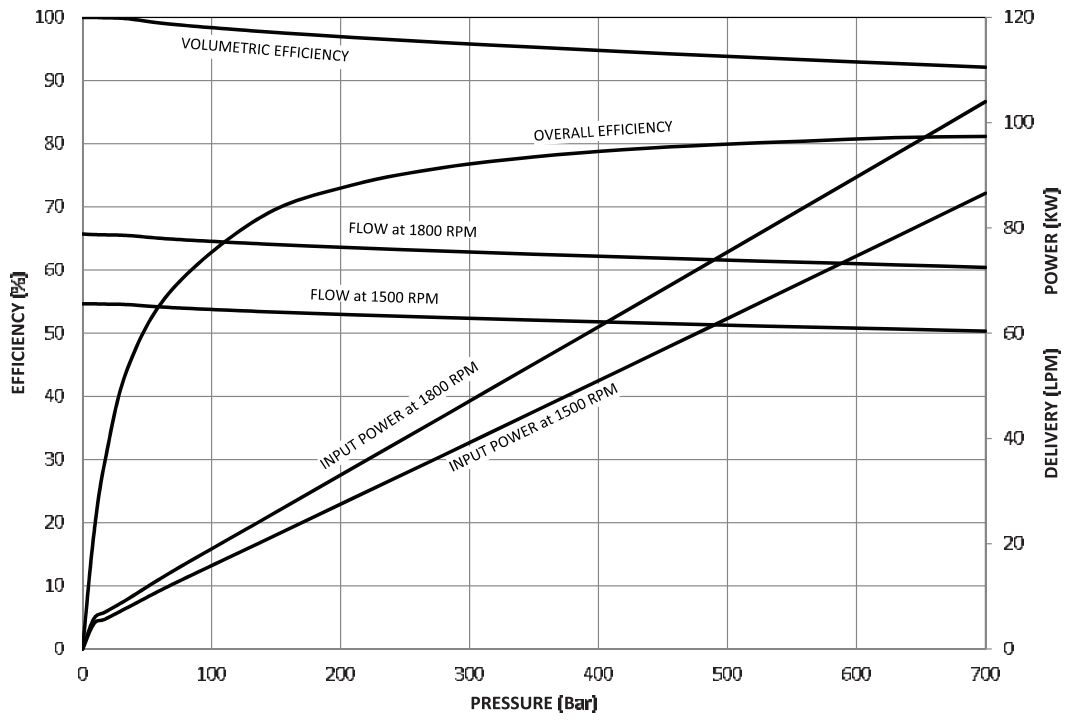

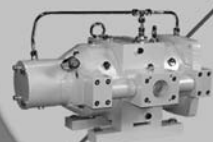

Oilgear Performance Data

■ PFBK052

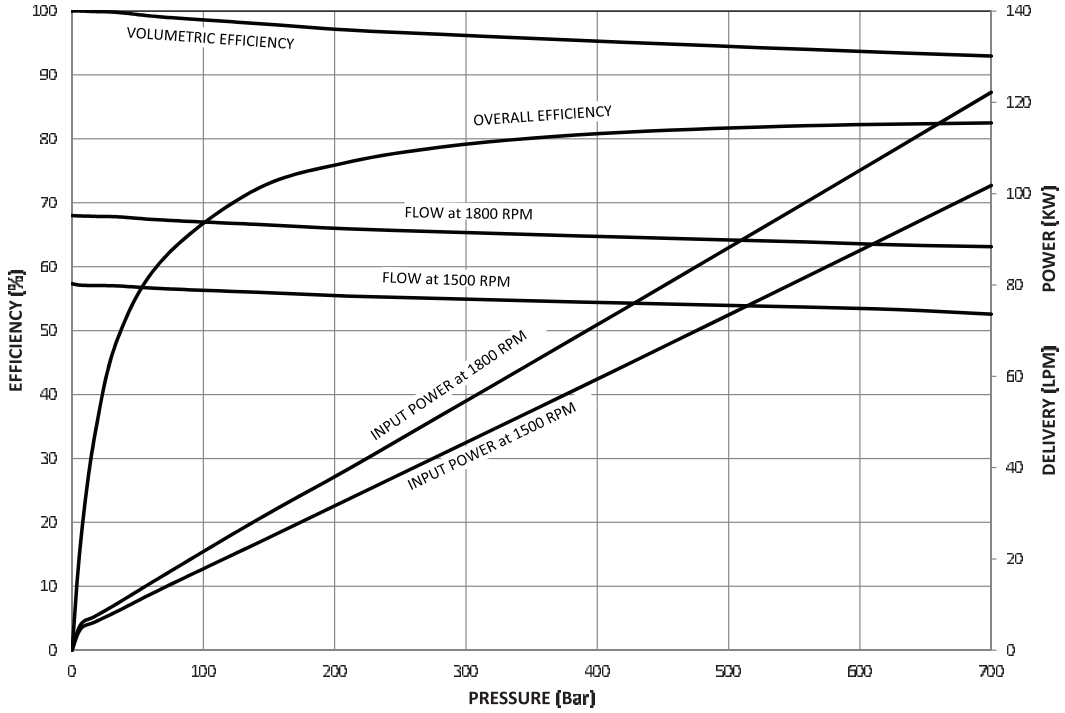

■ PFBK065

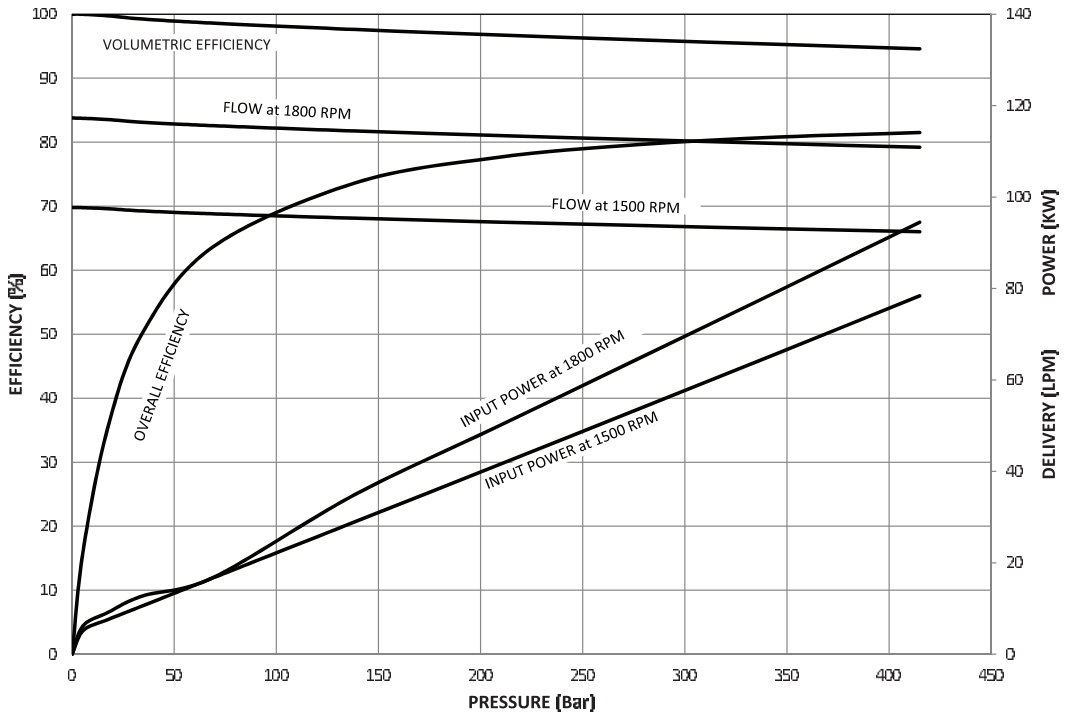



HOW TO ORDER – PFBK

BLOCK NUMBER EXPLANATION	1	2	3	4	5	6	7	8	9	10	11	12	13	14	15	16	17	18
HIGH PRESSURE PUMP EXAMPLE	P	F	B	K	B	033	H	*	B	A	R	S	L	R	D	NN	B	A

- 1 = UNIT
P = Pump
- 2 = TYPE
F = Fixed
- 3 = DESIGN
B = High Pressure Single Swash
- 4 = FRAME
K = Up to 63 ml/Rev
- 5 = STYLE
A = Separate Boost
B = Internal Boost (32 - 100 cSt)
- 6 = DISPLACEMENT
033 = 33 ml/Rev
043 = 43 ml/Rev
052 = 52 ml/Rev
065 = 65 ml/Rev
- 7 = DESIGN SERIES
H = Standard for Oil
- 8 = MODIFIER
* = Assigned by Factory
- 9 = DIMENSIONS
B = Metric with BSP Ports
- 10 = WORKING PRESSURE
A = 1000 Bar (Size 033)
7 = 700 Bar (Size 043, 052)
4 = 415 Bar (Size 065)
- 11 = ROTATION (Viewed from Drive Shaft End)
L = Counterclockwise (CCW)
Left Hand
R = Clockwise (CW) Right Hand
- 12 = MOUNTING
S = Standard Face Mount
F = Foot
- 13 = INLET POSITION (Viewed from Drive Shaft End)
L = Left
R = Right
- 14 = DISCHARGE POSITION (Viewed from Drive Shaft End)
L = Left
R = Right
- 15 = DISCHARGE CONNECTION BLOCK
D = Double Discharge
N = No Connection Block Fitted
S = Single Discharge
Z = Special
- 16 = SHAFT
NN = Standard Keyway
- 17 = SEALS
B = Buna N (Nitrile)
E = E.P.D.M.
V = Viton
Z = Special (Available on Request)
- 18 = END / REAR MOUNT
A = SAE 'A' Frame
B = SAE 'B' Frame
C = Closed End
F = FBA
J = H or J Vane V20
K = K Vane 20V, 25V

PFCM

HIGH PRESSURE AXIAL PISTON PUMPS

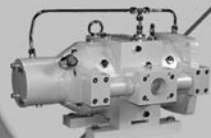

Double Sided Counterbalanced Swashblock

- Balanced design eliminates need for thrust bearings
- Provides long life
- Enables easy re-buildability
- Permits high rotational speeds

Delivery Valve Cartridge

- Rugged, high response, lightweight poppet construction assures long life
- Cartridge construction inlet and delivery valve assemblies allow ease of maintenance
- Positively seated inlet and delivery valves for high volumetric efficiency

Foot Mounting or Flange Mounting

- Select the mounting arrangement that suits the application

Single or Double Discharge

- Provides stepped volume control
- High/low flow capability permits horsepower limiting circuits
- Permits servicing two independent circuits at the same time

Swashmember with 9° Angle

- Results in low position head loading
- Allows high speed operation
- Design enables pump compatibility to high pressure and high shock loads

Hydrodynamic Thrust Bearing with Forced Lubrication

- Carries the thrust load giving long life and allows operation with low viscosity or special fluids

Steel Piston Shoes

- Hydrostatically balanced design reduces piston shoe load and provides lubrication for increased life
- Facilitates a high degree of contamination wear resistance
- Permits higher pressure operation with long life
- Allows operation with low viscosity or other special fluids including 95/5. Consult Oilgear for more information.

Inlet Valve Cartridge

- Cartridge construction inlet and delivery valve assemblies eases maintenance

Optional Internal Supercharge Pump

- Eliminates need for extra electric motor and external supercharge pump
- Lubricates and provides case flow for cooling the main pump

Through Drive Capabilities

- Allows mounting of additional pumps if necessary up to 50 hp (37,3 kw) capacity

Overload Sensing Device

- This unique, patented overload protection device provides electrical signal in the event of an out-of-balance axial piston load.

Pistons

- Twelve hardened steel pistons located in two stationary cylinders are not subject to centrifugal force thus reducing load and wear. This piston load is caused by pumping action only, therefore higher operating speeds are possible.

Polymer Coated Bearing with Forced Lubrication

- Enables operation with low viscosity or other special fluids
- Provides superior bearing life

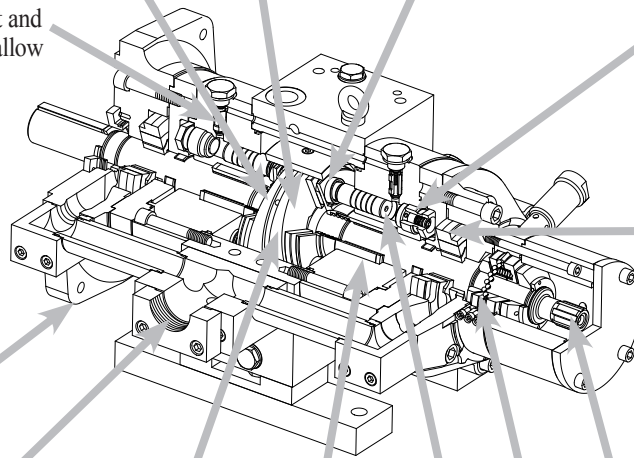

High Pressure

Up to 14500 psi (1000 bar) with most hydraulic fluids – 5000 psi (345 bar) with 95/5. Consult Oilgear for more information.

Heavy-Duty Construction

Many of these units have operated over 40,000 hours before inspection and reconditioning is necessary.

Wide Variety of Applications

High pressure test rigs, civil and marine projects, intensifier systems, extrusion and forging presses and other heavy-duty metal forming machines.

Oilgear Features and Benefits

SINGLE DISCHARGE PFCM

UNIT	THEORETICAL DISPLACEMENT		RATED CONTINUOUS PRESSURE		RATED DRIVE SPEED											
					1200 rpm*				1500 rpm*				1800 rpm*			
	in. ³ /rev.	ml/rev.	psi	bar	USgpm		lpm		INPUT		INPUT		INPUT		INPUT	
					USgpm	lpm	hp	kw	USgpm	lpm	hp	kw	USgpm	lpm	hp	kw
WITH INTEGRAL SUPERCHARGE																
PFCM066	4.26	69,8	14500	1000	19.2	72,8	213	159	24.0	91,0	266	198	28.8	109	319	238
PFCM086	5.46	89,5	10000	700	25.4	96,3	179	134	31.8	121	224	167	38.2	145	269	201
PFCM104	6.66	109,2	10000	700	31.0	118	218	163	38.8	147	273	204	46.6	177	328	245
PFCM130	8.34	136,7	6000	415	39.0	148	159	119	48.8	185	199	149	58.6	222	239	178

Note: With external supercharge, 80-to-100 psi (5,5-to-6,9 bar) is required
*At rated pressure.

DOUBLE DISCHARGE PFCM

UNIT	DISCHARGE #	DRIVE SPEED					
		1200 rpm		1500 rpm		1800 rpm	
		USgpm	lpm	USgpm	lpm	USgpm	lpm
PFCM066	1	10.0	37,8	12.4	47,2	15.0	56,6
	2	10.0	37,8	12.4	47,2	15.0	56,6
PFCM086	1	10.0	37,8	12.4	47,2	15.0	56,6
	2	15.6	58,8	19.4	73,6	23.4	88,4
PFCM104	1	15.6	58,8	19.4	73,6	23.4	88,4
	2	15.6	58,8	19.4	73,6	23.4	88,4
PFCM130	1	19.6	74,0	24.4	92,4	29.2	111
	2	19.6	74,0	24.4	92,4	29.2	111

DIMENSIONS (With Double Discharge Blocks*)

UNIT	L LENGTH**		W WIDTH †		H HEIGHT		WEIGHT			
	in.	mm	in.	mm	in.	mm	FOOT MOUNT		FLANGE MOUNT	
							lb.	kg	lb.	kg
PFCM066	32.4	823	20.6	522	14.4	367	681	309	633	287
PFCM086										
PFCM100										
PFCM130										

* All dimensions are approximate. For detailed information consult your factory representative.

† Width with single discharge = 20.0 in. (507 mm)

** Length of pump without integral supercharge = 30.8 in. (783 mm).

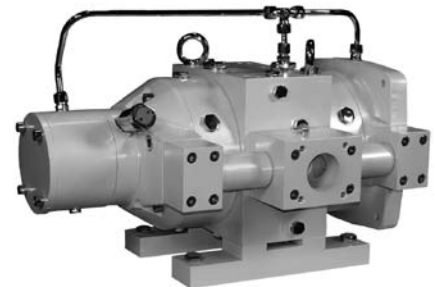

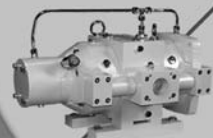

Oilgear Performance Data

■ PFCM066

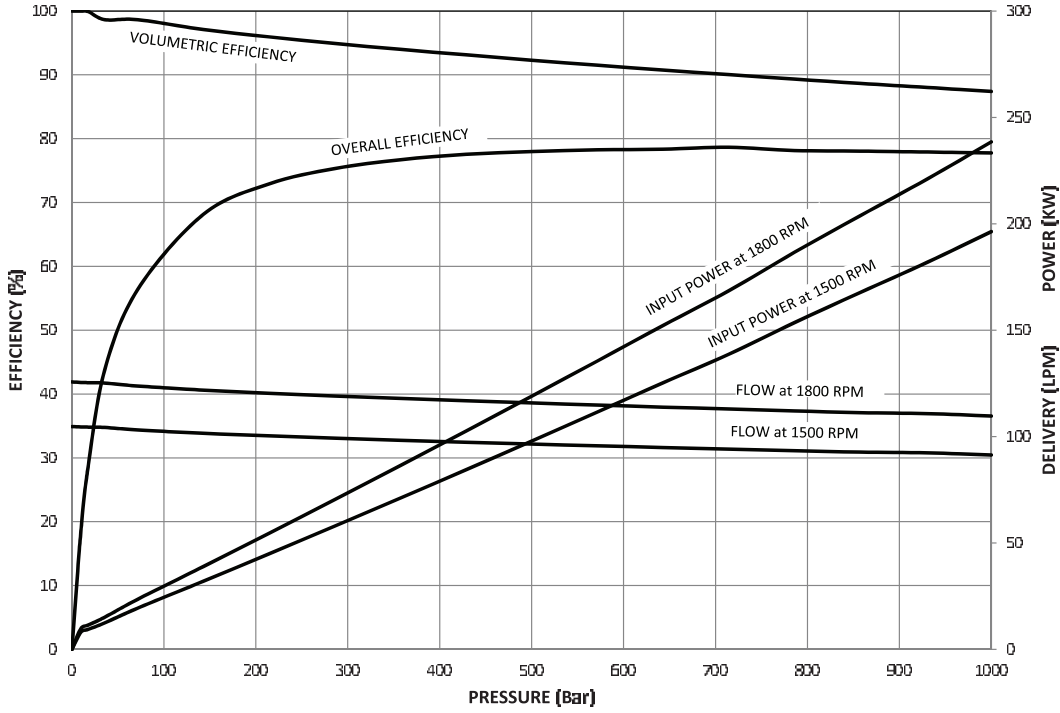

■ PFCM086

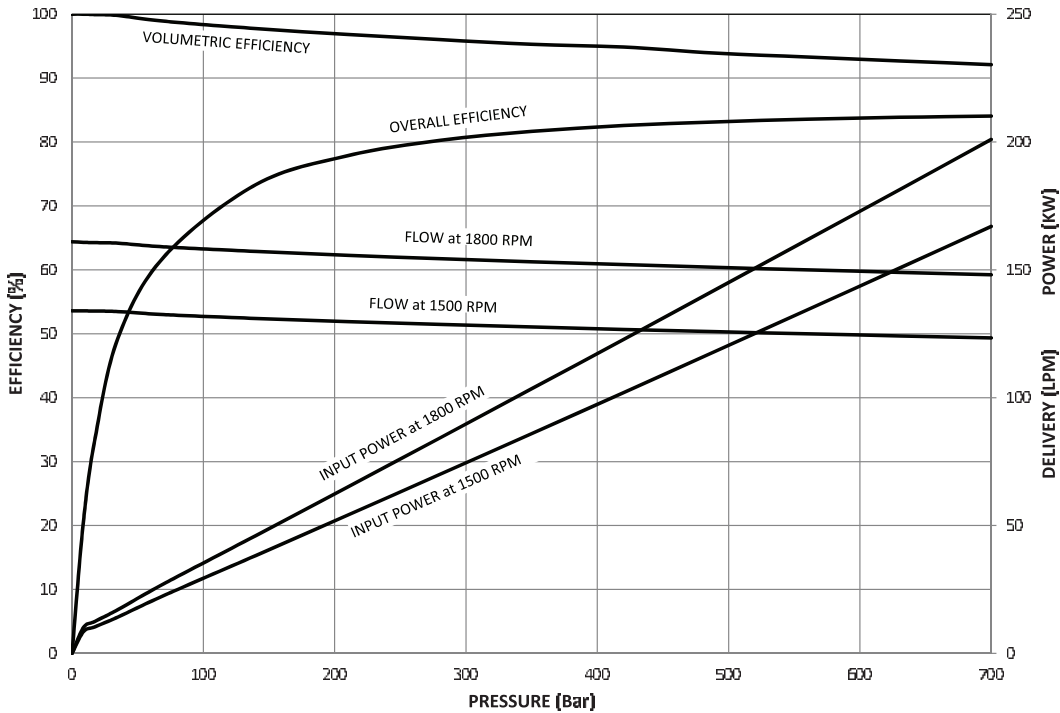



Oilgear Performance Data

■ PFCM104

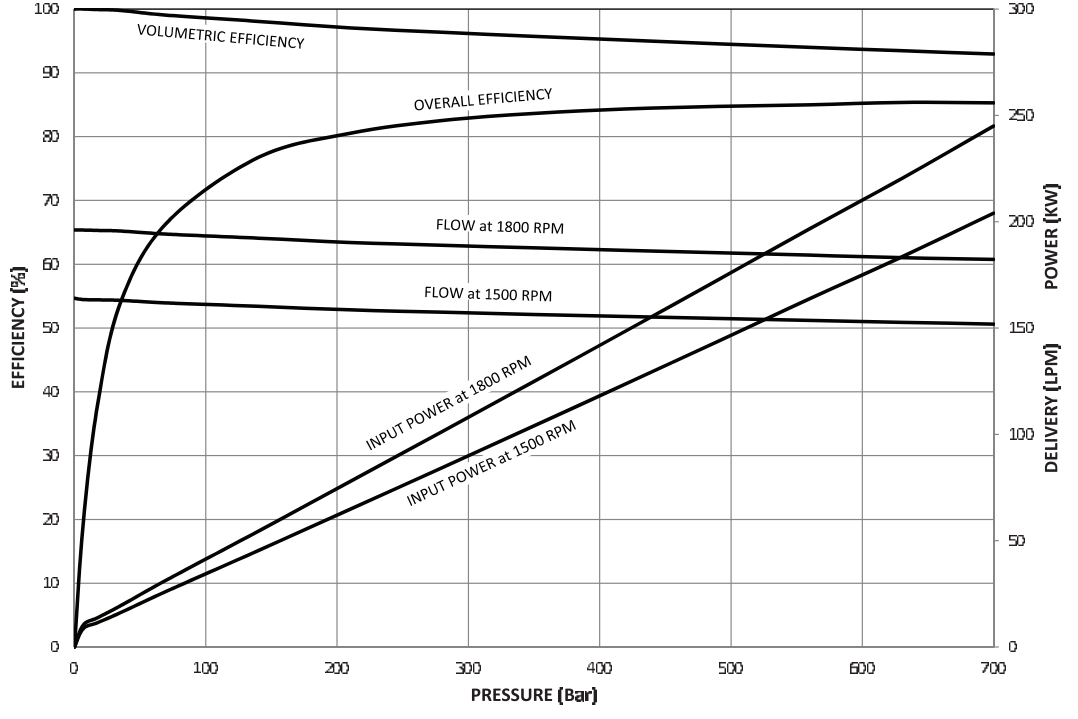

■ PFCM130

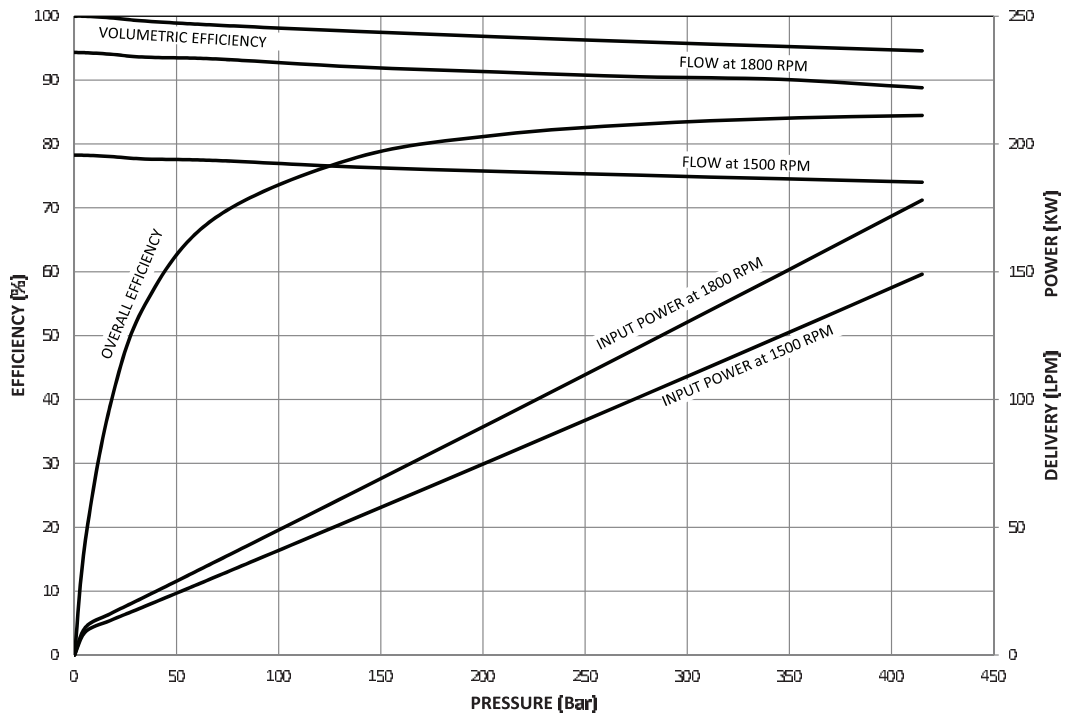

HOW TO ORDER – PFCM



BLOCK NUMBER EXPLANATION	1	2	3	4	5	6	7	8	9	10	11	12	13	14	15	16	17	18	19
HIGH PRESSURE PUMP EXAMPLE	P	F	C	M	B	066	H	*	B	A	R	S	L	R	D	NN	A	B	A

- | | |
|---|---|
| <p>1 = UNIT
P = Pump</p> <p>2 = TYPE
F = Fixed</p> <p>3 = DESIGN
C = Double End Swash</p> <p>4 = FRAME
M = Up to 160 ml/Rev</p> <p>5 = STYLE
A = Separate Boost
B = Internal Boost (32 - 100 cSt)</p> <p>6 = DISPLACEMENT
066 = 66 ml/Rev
086 = 86 ml/Rev
104 = 104 ml/Rev
130 = 130 ml/Rev</p> <p>7 = DESIGN SERIES
H = Standard for Oil</p> <p>8 = MODIFIER
* = Assigned by Factory</p> <p>9 = DIMENSIONS
B = Metric with BSP Ports</p> <p>10 = WORKING PRESSURE
A = 1000 Bar (Size 066)
7 = 700 Bar (Size 086, 104)
4 = 415 Bar (Size 130)</p> <p>11 = ROTATION (Viewed from Drive Shaft End)
L = Counterclockwise (CCW) Left Hand
R = Clockwise (CW) Right Hand</p> | <p>12 = MOUNTING
S = Standard Face Mount
F = Foot</p> <p>13 = INLET POSITION (Viewed from Drive Shaft End)
L = Left
R = Right</p> <p>14 = DISCHARGE POSITION (Viewed from Drive Shaft End)
L = Left
R = Right</p> <p>15 = DISCHARGE CONNECTION BLOCK
D = Double Discharge
N = No Connection Block Fitted
S = Single Discharge
Z = Special</p> <p>16 = SHAFT
NN = Standard Keyway</p> <p>17 = FAULT SWITCH
A = Micro Switch</p> <p>18 = SEALS
B = Buna N (Nitrile)
E = E.P.D.M.
V = Viton
Z = Special (Available on Request)</p> <p>19 = END / REAR MOUNT
A = SAE 'A' Frame
B = SAE 'B' Frame
C = Closed End
F = FBA
J = H or J Vane V20
K = K Vane 20V, 25V</p> |
|---|---|

Oilgear How to Order



PFCS

HIGH PRESSURE AXIAL PISTON PUMPS

Oilgear Features and Benefits

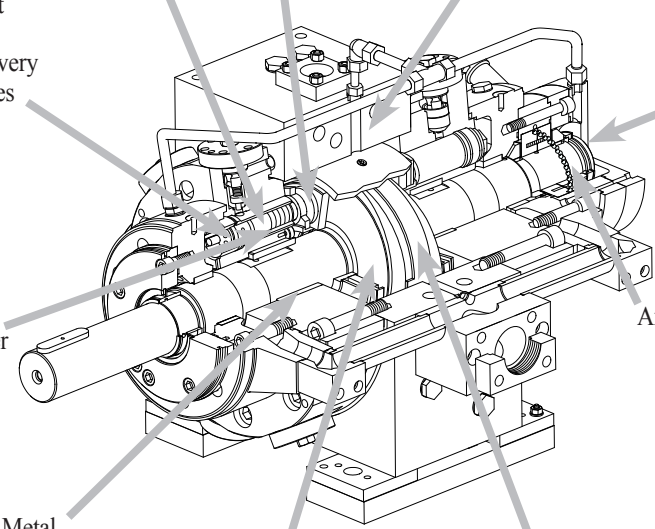

Pistons

- Eighteen hardened steel pistons located in two stationary cylinders are not subject to centrifugal force thus reducing load and wear. The piston load is caused by pumping only, therefore higher operating speeds are possible.

Steel Piston Shoes

- Hydrostatically balanced design reduces piston shoe load and provides lubrication for increased life
- Facilitates a high degree of contamination wear resistance
- Permits higher pressure operation with long life
- Allows operation with low viscosity or other special fluids including 95/5. Consult Oilgear for more information.

Three Separate Deliveries (1/3 each)

- Deliveries can be combined together in one circuit
- Deliveries can be completely separated in three circuits
- Deliveries can be any combination of two circuits
- Can provide limited power consumption
- Allows design flexibility

Cartridge Type Inlet and Outlet Check Valves

- Positive seating results in very high volumetric efficiencies
- Are easy to service

Replaceable Piston Sleeves

- Allows economical rebuilding without cylinder replacement

Precision Manufactured White Metal Bearings with Forced Lubrication

- Enables operating with low viscosity or other special fluids
- Provides superior bearing life

Optional Thru-Shaft

- Permits mounting of additional pumps

Axial Overload Sensing Devices

- Simple dependable design
- Senses unbalanced (piston load) condition by detecting shaft movement
- Provides shut-down or warning signal before damage occurs

Double Sided Counterbalanced Swashblock with Replaceable Swash Wear Plate

- Balanced design eliminates need for thrust bearings
- Provide long life
- Enables easy re-buildability
- Permits high rotational speeds

Swashmember with 8° Angle

- Results in low piston head loading
- Allows high speed operation
- Design enables pump compatibility to high pressure and high shock loads

Heavy-Duty Construction

Many of these units have operated over 40,000 hours before inspection and reconditioning is necessary.

Experience

Typical applications for these units include – open and closed die forging presses, piercing presses, coining presses, rubber pad presses, etc.

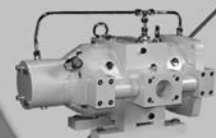

SINGLE DISCHARGE PFCS440 / PFCS580

UNIT	THEORETICAL DISPLACEMENT		RATED CONTINUOUS PRESSURE		RATED DRIVE SPEED											
					1200 rpm				1500 rpm				1800 rpm			
					INPUT*				INPUT*				INPUT*			
					USgpm	lpm	hp	kw	USgpm	lpm	hp	kw	USgpm	lpm	hp	kw
PFCS440	28.6	468	7250	500	135	511	649	484	169	640	812	606	203	769	976	728
PFCS580	35.8	587	5000	350	169	641	633	472	212	801	791	590	-	-	-	-

*Approximate at rated speed and pressure.

Note: External supercharge pressure of 150-to-180 psi (10,3-to-12,4 bar) is required.

MULTIPLE DISCHARGE PFCS440 / PFCS580

UNIT	NUMBER OF DISCHARGES	DISCHARGE #	RATED DRIVE SPEED							
			1200 rpm		1500 rpm		1800 rpm			
			USgpm	lpm	USgpm	lpm	USgpm	lpm		
PFCS440	2	1	45.0	171	56.3	213	67.7	257		
		2	90.0	341	113	427	135	514		
	3	1	45.0	171	56.3	213	67.7	257		
		2	45.0	171	56.3	213	67.7	257		
		3	45.0	171	56.3	213	67.7	257		
	PFCS580	2	1	56.5	214	70.5	267	-	-	
2			113	427	141	534	-	-		
3		1	56.5	214	70.5	267	-	-		
		2	56.5	214	70.5	267	-	-		
		3	56.5	214	70.5	267	-	-		

DISCHARGE BLOCKS

There is a wide and diverse variety of discharge blocks and integrated manifolds available incorporating valves for the various types of installations. Contact the factory with specific requirements.

DIMENSIONS* (Without Discharge Block)

UNIT	L LENGTH		W WIDTH		H HEIGHT		WEIGHT	
	in.	mm	in.	mm	in.	mm	lb.	kg
PFCS440	46.42	1179	24.57	624	22.72	577	2469	1120
PFCS580								

* All dimensions are approximate. For detailed information consult your factory representative.

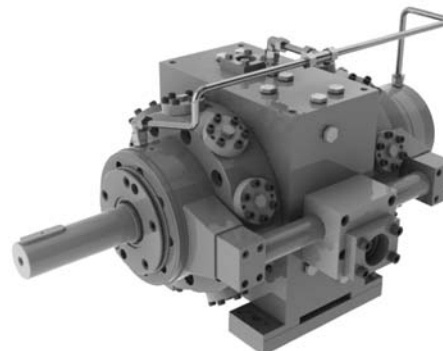



Oilgear Performance Data

PFCS440

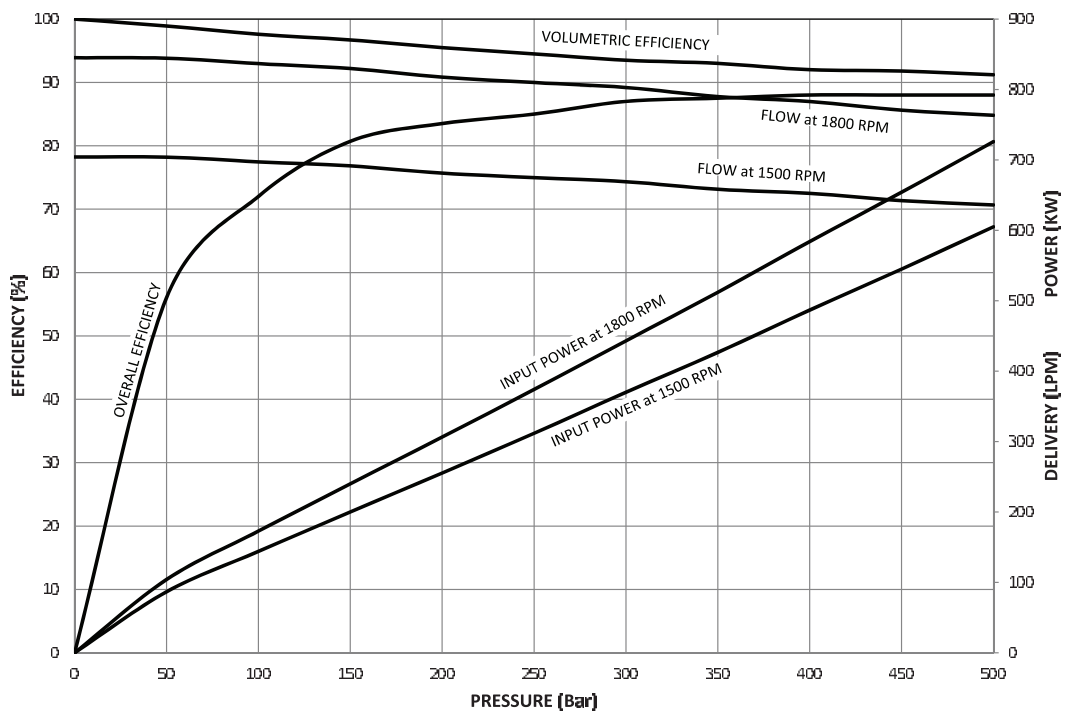

PFCS580

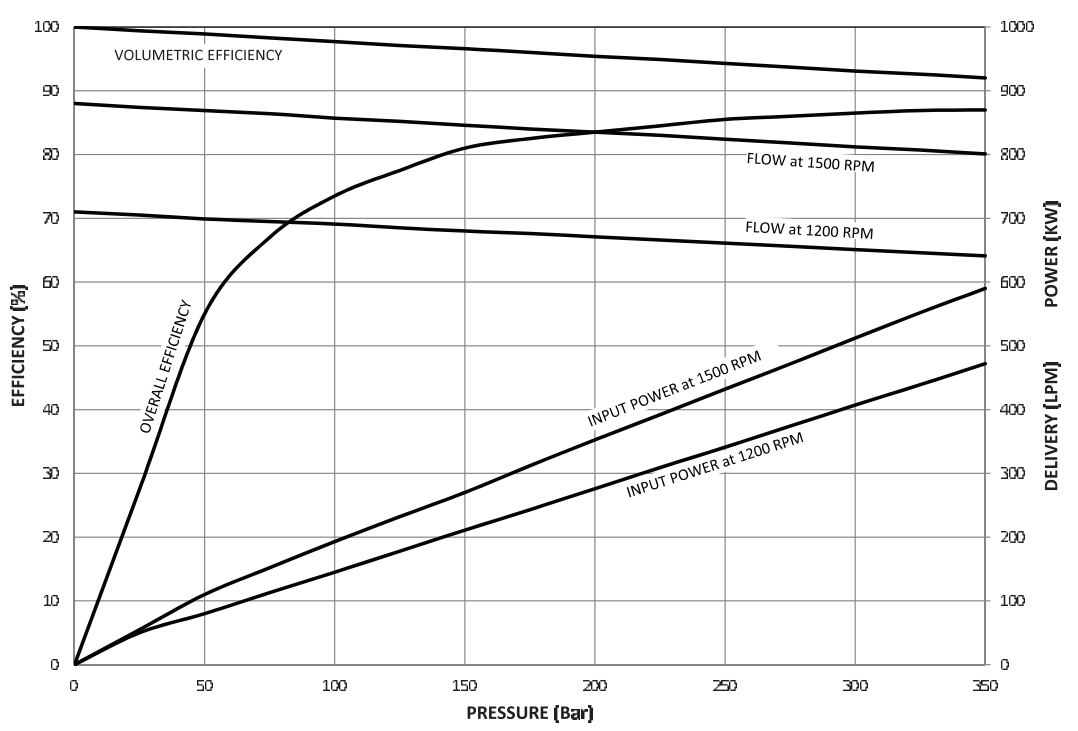

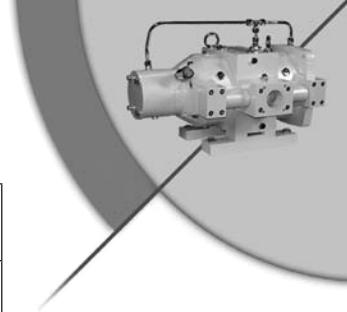

HOW TO ORDER – PFCS

BLOCK NUMBER EXPLANATION	1	2	3	4	5	6	7	8	9	10	11	12	13	14	15	16	17
HIGH PRESSURE PUMP EXAMPLE	P	F	C	S	440	A	*	M	500	L	F	R	L	N	NN	A	B

- | | |
|--|--|
| <p>1 = UNIT
P = Pump</p> <p>2 = TYPE
F = Fixed</p> <p>3 = DESIGN
C = Dual Swash</p> <p>4 = FRAME
S = Up to 630 ml/Rev</p> <p>5 = DISPLACEMENT
440 = 440 ml/Rev
580 = 580 ml/Rev</p> <p>6 = DESIGN SERIES
A = Standard for Mineral Oil</p> <p>7 = MODIFIER
* = Designated by Factory</p> <p>8 = DIMENSIONS
M = Metric</p> <p>9 = MAX. WORKING PRESSURE
500 = For 440 Size
350 = For 580 Size</p> <p>10 = ROTATION (Facing Drive Shaft)
L = Counterclockwise (CCW)
Left Hand
R = Clockwise (CW) Right Hand</p> <p>11 = MOUNTING
F = Foot Mounting (Standard)</p> | <p>12 = INLET POSITION (Facing Drive Shaft)
Note: Inlet is always on the opposite side of discharge
L = Left Side with Horizontal Connection
R = Right Side with Horizontal Connection
A = Left Side with Vertical Connection
B = Right Side with Vertical Connection</p> <p>13 = DISCHARGE POSITION (Facing Drive Shaft)
Note: Discharge Position is always on the opposite side of inlet
L = Left Side
R = Right Side</p> <p>14 = DISCHARGE BLOCK
N = No Connection Block Fitted
(Available as a separate item; consult Oilgear)</p> <p>15 = SHAFT
NN = Standard Key</p> <p>16 = FAULT SWITCH
A = Micro Switch and Connector</p> <p>17 = SEALS
B = Buna N
E = E.P.D.M.
V = Viton
Z = Special</p> |
|--|--|



Oilgear

World Headquarters

The Oilgear Company

2300 South 51st Street Milwaukee, WI USA 53219
phone: 414/327-1700 fax: 414/327-0532

www.oilgear.com

For more information about your application or the products in this brochure, please contact your nearest Oilgear facility.



BRAZIL

Oilgear do Brazil Hydraulica Ltd.

CANADA

The Oilgear Company

FRANCE

Oilgear Towler S.A.

GERMANY

Oilgear Towler GmbH

INDIA

Oilgear Towler Polyhydron Pvt. Ltd.
Towler Automation Pvt. Ltd.

ITALY

Oilgear Towler S.r.l.

JAPAN

The Oilgear Japan Company

KOREA

Oilgear Towler Korea Co. Ltd.

MEXICO

Oilgear Mexicana S.A. de C.V.

SPAIN

Oilgear Towler S.A.

TAIWAN

Oilgear Towler Taiwan Co. Ltd.

UNITED KINGDOM

Oilgear Towler Ltd.

UNITED STATES OF AMERICA

The Oilgear Company
Olmsted
Clover Industries