



ONE-WAY PUMP SUCTION & RETURN VALVE

FOR OILGEAR TYPE "CG" & "D" UNITS

REFERENCE BULLETINS

- Type "CG" Constant Delivery Pumps (sizes 2 thru 60)-----946000
- Type "CG" Constant Delivery Pumps (sizes 100 and 150) ---- 946001
- Type "D" Variable Delivery Pumps-----947000

I. CONSTRUCTION.

The one-way pump suction and return valve, bolted to the bottom of the pump case, consists of a back pressure relief valve (214) and a suction check valve (209) enclosed in a body (200) and flange (212). Some valves may be modified from those described for special applications.

II. PRINCIPLE OF OPERATION.

Supercharge pressure is generally ported from the gear pump to port 22 of the suction valve. The suction check valve (209) retains supercharge and return fluid in the suction valve and pump return port, yet allows the pump to draw fluid from the reservoir thru pipe installed in port 5 if the supercharge and return volume is insufficient. The backpressure relief valve (214) (BPRV) limits supercharge and return pressure. The BPRV exhausts thru pipe installed in port 2. NOTE: Pump ports 6 and 7 should be open to the reservoir. If pump delivers from port "A," suction valve (200) covers port 17 and a blind flange (224) covers port 16. If pump delivers from port "B" suction valve and blind flange positions are reversed.

III. SPECIFICATIONS.

Back pressure relief valves for one-way units are normally set at 35 psi.

A. Approximate pressure variation for each 1/16 inch shim, in psi.

B. Maximum total thickness of shims permitted.

Pump Sizes	A	B
2, 4, 8, 12	5	5/16
20	1.5	7/16
35	2	7/16
60, 100, 150	1.25	13/16

IV. MALFUNCTIONS AND CAUSES.

Excessive noise in pump is usually caused by air entering the system at the suction valve gaskets or port 5 suction pipe. Be sure bolts and pipe are tight. It may also be caused by cavitation due to restricted passages or low back pressure. Low back pressure is usually caused by a sticky BPRV plunger (214) or a faulty suction check valve (209). Insufficient pump volume or pressure may be caused by excessive leakage past blind flange (224).

V. TESTING AND ADJUSTING.

To check back pressure relief valve setting in type "D" pumps, insert a low pressure gage in port 12 and run the unit at neutral. If port 12 is being used, and when checking type "CG" pumps, insert the gage in the return port of the pump. Gage reading will be back pressure. (Check any connections from the circuit to the return port to be sure supercharge fluid is not being bypassed somewhere in the circuit).

To adjust back pressure, remove inspection cover on side of reservoir (it may be necessary to drain some fluid first). If reservoir base does not have an inspection cover, it will be necessary to disconnect the pump from the circuit and drive motor to raise it so the BPRV can be shimmed. Remove cover (218) over BPRV and add shims (216) to increase pressure, remove shims to decrease pressure. See III. A and B. CAUTION: Do not install solid shims (216) between plunger (214) and spring (215). * (See page 4).

VI. DISASSEMBLY.

Tag all O'rings, gaskets, seals and shims so they will be returned to their original positions. Remove all piping from valve and valve from pump.

Continued on page 4

IX. PARTS LIST

Part No.	Description	Part No.	Description
200.	Body, Suction Valve	216.	Shims, BPRV
200A.	Screw, Sock. Hd. Cap	217.	Gasket, Cap
203.	Gasket, Spacer	218.	Cap, BPRV
204.	Spacer, Seal	218A.	Screw, Sock. Hd. Cap
208.	Cage, Check Valve	218B.	Wire, Soft Iron
209.	Disc, Suction Valve	223.	Gasket, Body
210.	Seat, Check Valve	224.	Flange, Blind
211.	Gasket, Flange	224A.	Screw, Sock. Hd. Cap
212.	Flange, Check Valve	225.	Spacer, Gasket
214.	Plunger, BPRV	226.	Gasket, Spacer
215.	Spring, BPRV	227.	Plug, Pipe

When ordering replacement parts, be sure to include pump serial number, data sheet (DS) number and part number.

Specify type of hydraulic fluid used.

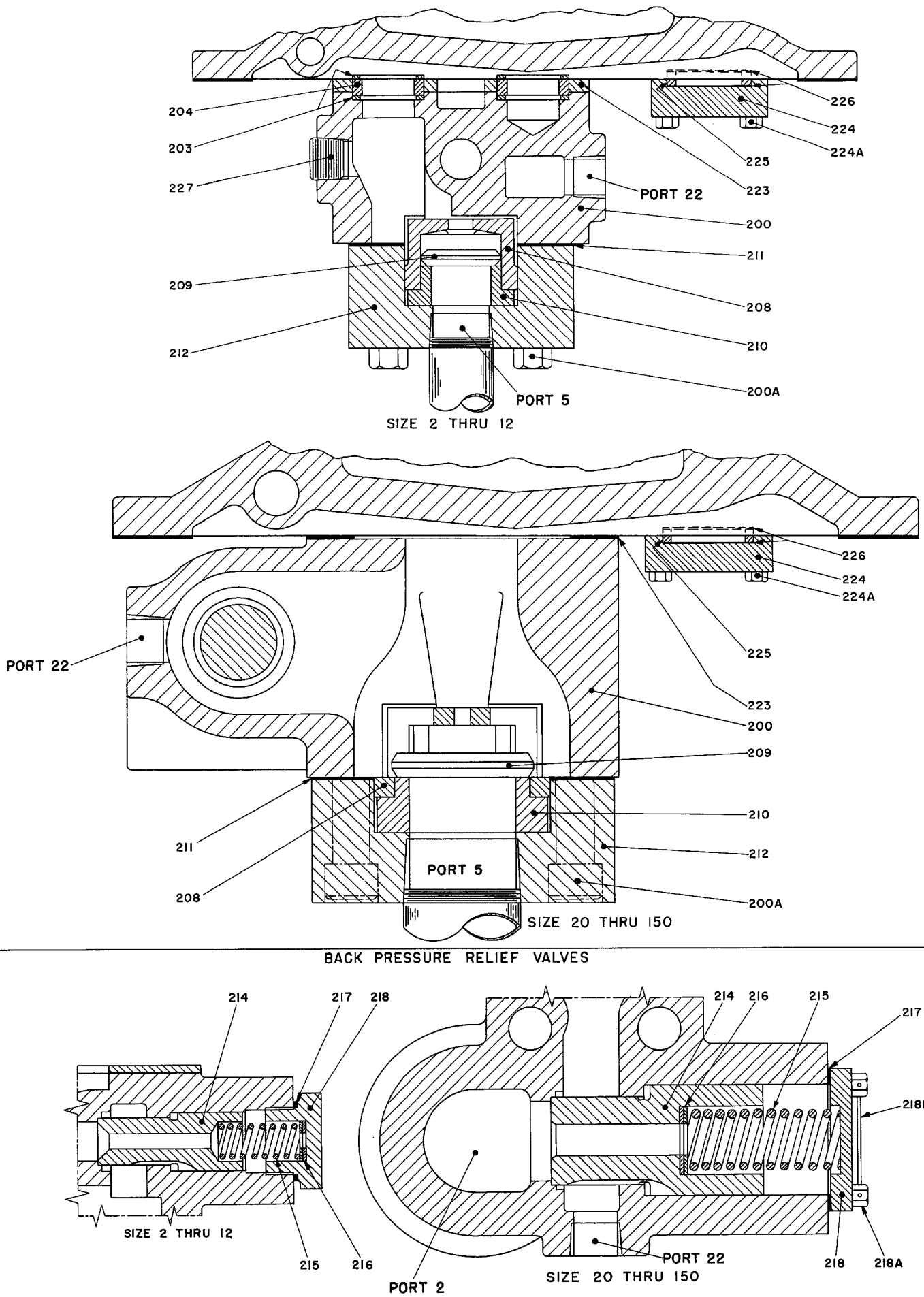

Figure 1. Parts Drawing, One-Way Suction and Return Valve. DS-947913 (504365).

Suction Check Valve. Remove suction flange (212). The check valve cage (208) has a 0.002" press fit in suction flange. Complete disassembly of flange and cage is usually not necessary for inspection and cleaning.

Back Pressure Relief Valve. Remove cover plug or cap (218). The shims (216), spring (215) and plunger (214) are free to be removed. Plunger is tapped so a threaded rod can be inserted to withdraw it.

VII. INSPECTION.

Suction Check Valve. Check for dirt on the check valve seat (210) or disk (209) and examine surfaces for scratches or grooves. Check for cracked seat.

Back Pressure Relief Valve. Check valve plunger seat for scoring or foreign matter. Clean V-slot in plunger. Polish or lap sticky plunger. Clearance between plunger and valve body should be 0.001" at both diameters. Be sure hole thru plunger is not blocked.

VIII. ASSEMBLY.

Anneal all copper gaskets. Clean all parts thoroughly. If BPRV plunger was lapped, make certain all compound has been removed. Insert BPRV plunger (214), spring (215), shims (216) and secure cover (218). * Insert suction check valve seat (210) and disk (209), and press cage (208) into suction flange (212). Mount suction flange assembly with gasket (211) on valve body (200). Draw bolts up evenly and very tightly. Bolt entire suction valve assembly with seals or gaskets, spacers and spacer gaskets in place on bottom of pump. Draw suction valve mounting bolts up evenly and very tightly as all seals must be air tight. If blind flange (224) was removed, assemble it to pump case. Install suction and exhaust pipes. Use pipe compounds sparingly or Teflon tape and only on male threads. Suction pipe in port 5 must be turned in very tightly to prevent the pump from sucking air. Connect piping to port 22 and remount pump on reservoir

*If a flange type BPRV cover is used, insert hollow shims or washers between plunger and spring and secure cover screws with soft iron locking wire.